

THROUGH
SAMSAARA

DRAWING INDEX

EX.01.00	DRAWING INDEX	EX.01.34	BEGIN HERE -1
EX.01.01	EXECUTIVE SUMMARY	EX.01.35	BEGIN HERE-2
EX.01.02	THESIS STATEMENT	EX.01.36	BEGIN HERE-3
EX.01.03	CONCEPTUAL APPROACH	EX.01.37	BEGIN HERE-4
EX.01.04	CLIENT	EX.01.38	CALM IN YOU HANDS -1
EX.01.05	VENUE	EX.01.39	CALM IN YOU HANDS -2
EX.01.06	AUDIENCE	EX.01.40	THE MOMENT THAT BREATHES -1
EX.01.07	GOALS	EX.01.41	THE MOMENT THAT BREATHES -2
EX.01.08	INTERPRETIVE APPROACH		
EX.01.09	CONTENT OUTLINE	EX.02.01	SCHEDULES & LISTS
EX.01.10	CONCEPT FLOOR PLAN	EX.02.02	SCHEDULES-1
EX.01.11	OVERVIEW	EX.02.03	SCHEDULES-2
EX.01.12	THROUGH SAMBARA -1	EX.02.04	SPECIFICATIONS
EX.01.13	THROUGH SAMBARA -2		
EX.01.14	THROUGH SAMBARA -3	EX.03.01	PLANS & SECTIONS
EX.01.15	WHAT IS ZEN -1	EX.03.02	SYMBOLS LISTS
EX.01.16	WHAT IS ZEN -2	EX.03.03	GENERAL PLAN
EX.01.17	WHAT IS ZEN -3	EX.03.04	DIMENSION PLAN
EX.01.18	CONSUMABLE ZEN -1	EX.03.05	GRAPHIC LOCATION PLAN
EX.01.19	CONSUMABLE ZEN -2	EX.03.06	OVERALL SECTION
EX.01.20	CONSUMABLE ZEN -3		
EX.01.21	AUTHENTIC ZEN -1	EX.04.01	GRAPHIC ELEMENTS
EX.01.22	AUTHENTIC ZEN -2	EX.04.02	GRAPHIC LOOK & FEEL
EX.01.23	AUTHENTIC ZEN -3	EX.04.03	LOGO & TYPOGRAPHY
EX.01.24	THREE ESSENCE OF ZEN -1	EX.04.04	EXTERIOR POSTERS
EX.01.25	THREE ESSENCE OF ZEN -2		
EX.01.26	NOTHING STAYS -1	EX.05.01	EXHIBIT AREA DETAILS
EX.01.27	NOTHING STAYS -2	EX.05.02	DETAILS -1
EX.01.28	NOTHING STAYS -3	EX.05.03	DETAILS -2
EX.01.29	NOTHING HOLDS -1	EX.05.04	DETAILS -3
EX.01.30	NOTHING HOLDS -2	EX.05.05	DETAILS -4
EX.01.31	NOTHING HOLDS -3	EX.05.06	DETAILS -5
EX.01.32	NOTHING STANDS -1	EX.05.07	DETAILS -6
EX.01.33	NOTHING STANDS -2	EX.05.08	DETAILS -7
		EX.05.09	DETAILS -8



PROJECT
THROUGH SAMBARA

DRAWN BY
SUJIN HWANG

SITE
60 WALL STREET
ARTRIUUM, NYC

CLIENT
BLOOMBERG
PHILANTHROPIES

NOTES
DRAWINGS FOR
DESIGN INTENT ONLY

KEY PLAN

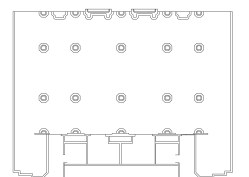

DATE
DEC 12, 2025

SCALE
AS NOTED

DRAWING
DRAWING INDEX

DRAWING NO.
EX.01.00

EXECUTIVE SUMMARY



SUJIN HWANG



PROJECT
THROUGH SAMSARA

DRAWN BY
SUJIN HWANG

SITE
60 WALL STREET
ARTRIUUM, NYC

CLIENT
BLOOMBERG
PHILANTHROPIES

NOTES
DRAWINGS FOR
DESIGN INTENT ONLY

KEY PLAN

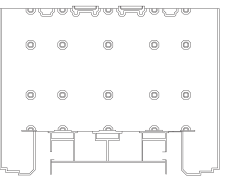

DATE
DEC 12, 2025

SCALE
AS NOTED

DRAWING
EXECUTIVE SUMMARY

DRAWING NO.
EX.01.01

THESIS STATEMENT

In contemporary New York, “Zen” is often reduced to a marketable image of calm—seen in apps, interiors, and wellness trends—detached from its roots in harmony, impermanence, and mindful stillness.

This thesis reinterprets Zen beyond commercial minimalism, translating its material and sensory qualities into exhibition design that invites contemplation over consumption, proposing Zen as a renewed urban way of being.

SUJIN HWANG



PROJECT
THROUGH SAMSARA

DRAWN BY
SUJIN HWANG

SITE
60 WALL STREET
ARTRIUUM, NYC

CLIENT
BLOOMBERG
PHILANTHROPIES

NOTES
DRAWINGS FOR
DESIGN INTENT ONLY

KEY PLAN

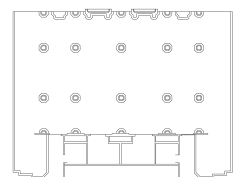

DATE
DEC 12, 2025

SCALE
AS NOTED

DRAWING
THESIS STATEMENT

DRAWING NO.
EX.01.02

CONCEPTUAL APPROACH

“Zen in the City That Never Sleeps”

New York runs on constant speed and pressure, and everyday life easily becomes overwhelming. This exhibition explores how Zen can still function within that environment.

Zen does not require a quiet place or a slow lifestyle.

It begins through basic practices such as observing, breathing, and pausing. When these simple actions are repeated, moments of clarity and awareness can emerge even in a fast-paced city.

As visitors move through the exhibition, they begin to notice how the thoughts and roles they hold onto are formed and released, allowing them to understand the essence of Zen within the reality of New York life.



PROJECT
THROUGH SAMSARA

DRAWN BY
SUJIN HWANG

SITE
60 WALL STREET
ARTRIUUM, NYC

CLIENT
BLOOMBERG
PHILANTHROPIES

NOTES
DRAWINGS FOR
DESIGN INTENT ONLY

KEY PLAN

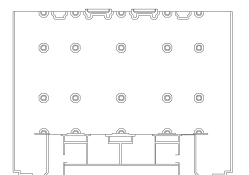

DATE
DEC 12, 2025

SCALE
AS NOTED

DRAWING
CONCEPTUAL
APPROACH

DRAWING NO.

EX.01.03

CLIENT

BLOOMBERG PHILANTHROPIES

is a global philanthropic organization founded by Michael R. Bloomberg. Headquartered in New York City, it focuses on advancing public health, education, the arts, the environment, and government innovation. The foundation supports initiatives worldwide, channeling resources to cities and organizations to improve lives and create lasting change.



NYC WELLBEING

Focuses on improving quality of life for New Yorkers.

PUBLIC HEALTH

Mental health and stress reduction align with their mission.

URBAN SOLUTIONS

Data-driven approach fits the city-stress context of the exhibition.

ARTS & IMPACT

Strong supporter of cultural projects with public value.



SUJIN HWANG



PROJECT

THROUGH SAMSARA

DRAWN BY

SUJIN HWANG

SITE

60 WALL STREET
ARTRIUUM, NYC

CLIENT

BLOOMBERG
PHILANTHROPIES

NOTES

DRAWINGS FOR
DESIGN INTENT ONLY

KEY PLAN

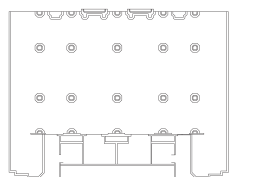

DATE

DEC 12, 2025

SCALE

AS NOTED

DRAWING

CLIENT

DRAWING NO.

EX.01.04

VENUE

60 WALL STREET ATRIUM

A public yet corporate space in New York's Financial District, the atrium embodies the tension between movement and stillness — an ideal setting to reintroduce Zen into urban life.



PROJECT
THROUGH SAMSARA

DRAWN BY
SUJIN HWANG

SITE
60 WALL STREET
ARTRIUM, NYC

CLIENT
BLOOMBERG
PHILANTHROPIES

NOTES
DRAWINGS FOR
DESIGN INTENT ONLY

KEY PLAN

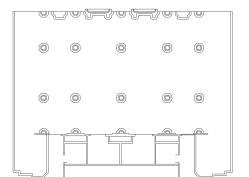

DATE
DEC 12, 2025

SCALE
AS NOTED

DRAWING
VENUE

DRAWING NO.
EX.01.05

AUDIENCE

PRIMARY

Young professionals in New York who live under constant pressure and seek simple, approachable practices for balance and reflection.



SECONDARY

Commuters, tourists, and casual visitors who pass through the atrium and are open to brief, sensory pauses in their fast daily flow.



PROJECT
THROUGH SAMSARA

DRAWN BY
SUJIN HWANG

SITE
60 WALL STREET
ARTRIUM, NYC

CLIENT
BLOOMBERG
PHILANTHROPIES

NOTES
DRAWINGS FOR
DESIGN INTENT ONLY

KEY PLAN

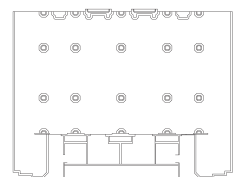

DATE
DEC 12, 2025

SCALE
AS NOTED

DRAWING
AUDIENCE

DRAWING NO.
EX.01.06

GOALS

PROJECT GOALS

Create a public exhibition where New York professionals can experience the core concepts of Zen amid high stress.

Propose a practice-based approach to Zen that works within an urban environment.

EDUCATION GOALS

Help visitors understand impermanence, emptiness, and non-attachment not as complex philosophy but through everyday language and direct experience.

Show that Zen is not tied to special spaces but begins with practice here and now.

EXPERIENCE GOALS

Provide short, intuitive moments of practice that interrupt the fast rhythm of New York.

Encourage visitors to notice their current state and release what they have been holding onto.

Leave them with simple practices they can carry into their everyday lives.



PROJECT

THROUGH SAMSARA

DRAWN BY

SUJIN HWANG

SITE

60 WALL STREET
ARTRIUUM, NYC

CLIENT

BLOOMBERG
PHILANTHROPIES

NOTES

DRAWINGS FOR
DESIGN INTENT ONLY

KEY PLAN

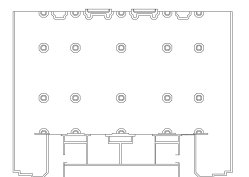

DATE

DEC 12, 2025

SCALE

AS NOTED

DRAWING

GOALS

DRAWING NO.

EX.01.07

INTERPRETIVE APPROACH

COGNITIVE SHIFT MODEL

DISRUPTION: BREAKING THE CITY'S RHYTHM

The exhibition introduces a brief pause that interrupts New York's constant speed, allowing visitors to step out of their automatic patterns.

REFRAMING: SEEING YOURSELF DIFFERENTLY

Through Zen concepts—impermanence, emptiness, non-attachment—visitors reconsider the thoughts, roles, and identities they've been holding onto.

INTEGRATION: CARRYING ZEN INTO DAILY LIFE

Simple, repeatable practices such as pausing, noticing, and letting go help visitors weave the experience back into their everyday routine.



PROJECT

THROUGH SAMSARA

DRAWN BY

SUJIN HWANG

SITE

60 WALL STREET
ARTRIUUM, NYC

CLIENT

BLOOMBERG
PHILANTHROPIES

NOTES

DRAWINGS FOR
DESIGN INTENT ONLY

KEY PLAN

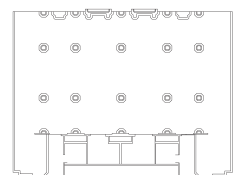

DATE

DEC 12, 2025

SCALE

AS NOTED

DRAWING

INTERPRETIVE
APPROACH

DRAWING NO.

EX.01.08

CONTENT OUTLINE



PROJECT
THROUGH SAMSARA

DRAWN BY
SUJIN HWANG

SITE
60 WALL STREET
ARTRIUM, NYC

CLIENT
BLOOMBERG
PHILANTHROPIES

NOTES
DRAWINGS FOR
DESIGN INTENT ONLY

KEY PLAN

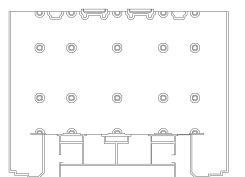

DATE
DEC 12, 2025

SCALE
AS NOTED

DRAWING
ELEVATION OUTLINE

DRAWING NO.
EX.01.09

CONCEPT FLOOR PLAN

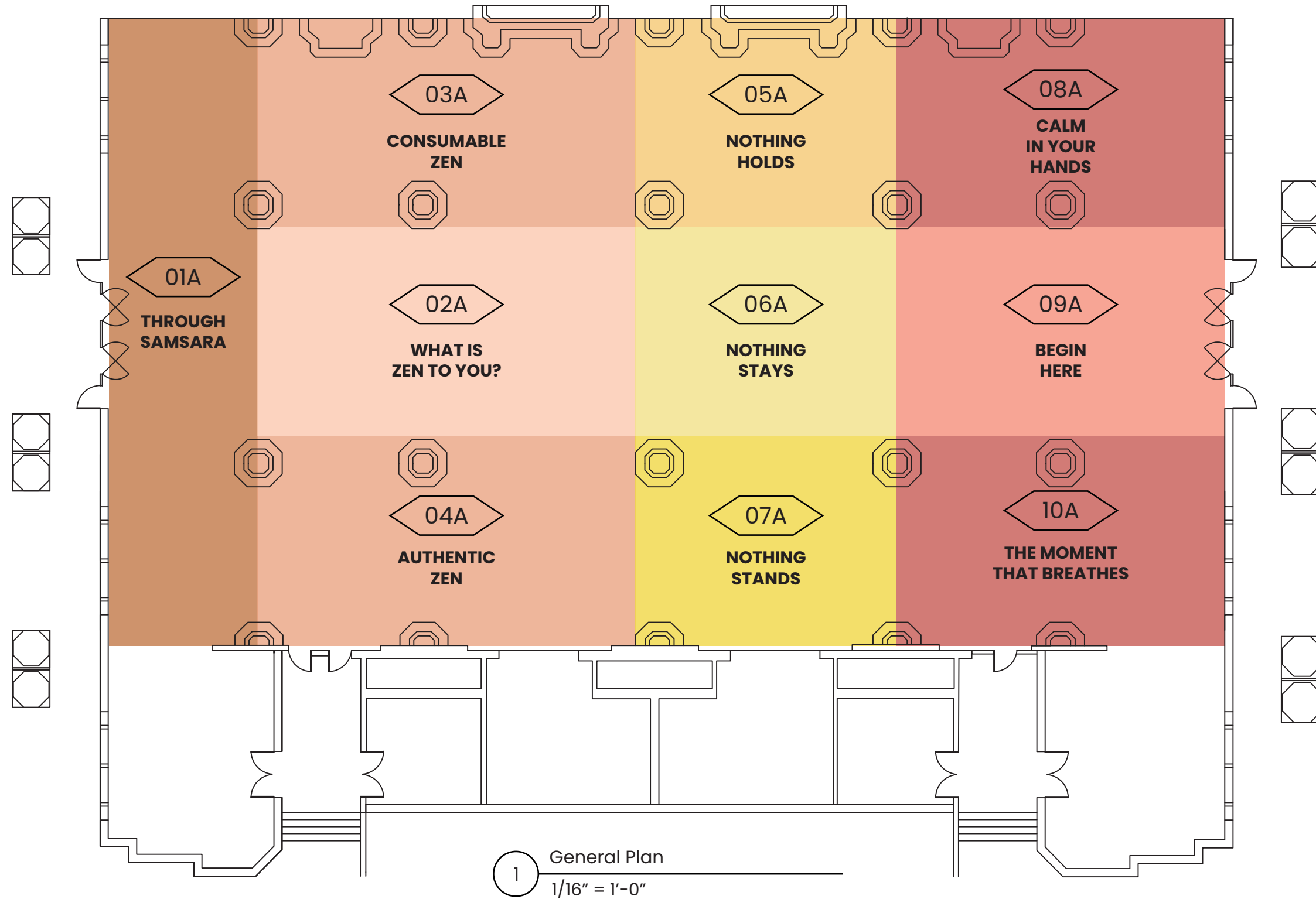

1 General Plan
1/16" = 1'-0"

SUJIN HWANG



PROJECT
THROUGH SAMSARA

DRAWN BY
SUJIN HWANG

SITE
60 WALL STREET
ARTRIUM, NYC

CLIENT
BLOOMBERG
PHILANTHROPIES

NOTES
DRAWINGS FOR
DESIGN INTENT ONLY

KEY PLAN

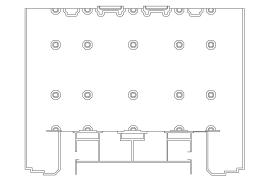

DATE
DEC 12, 2025

SCALE
AS NOTED

DRAWING
CONCEPT FLOOR
PLAN

DRAWING NO.
EX.01.10

OVERVIEW

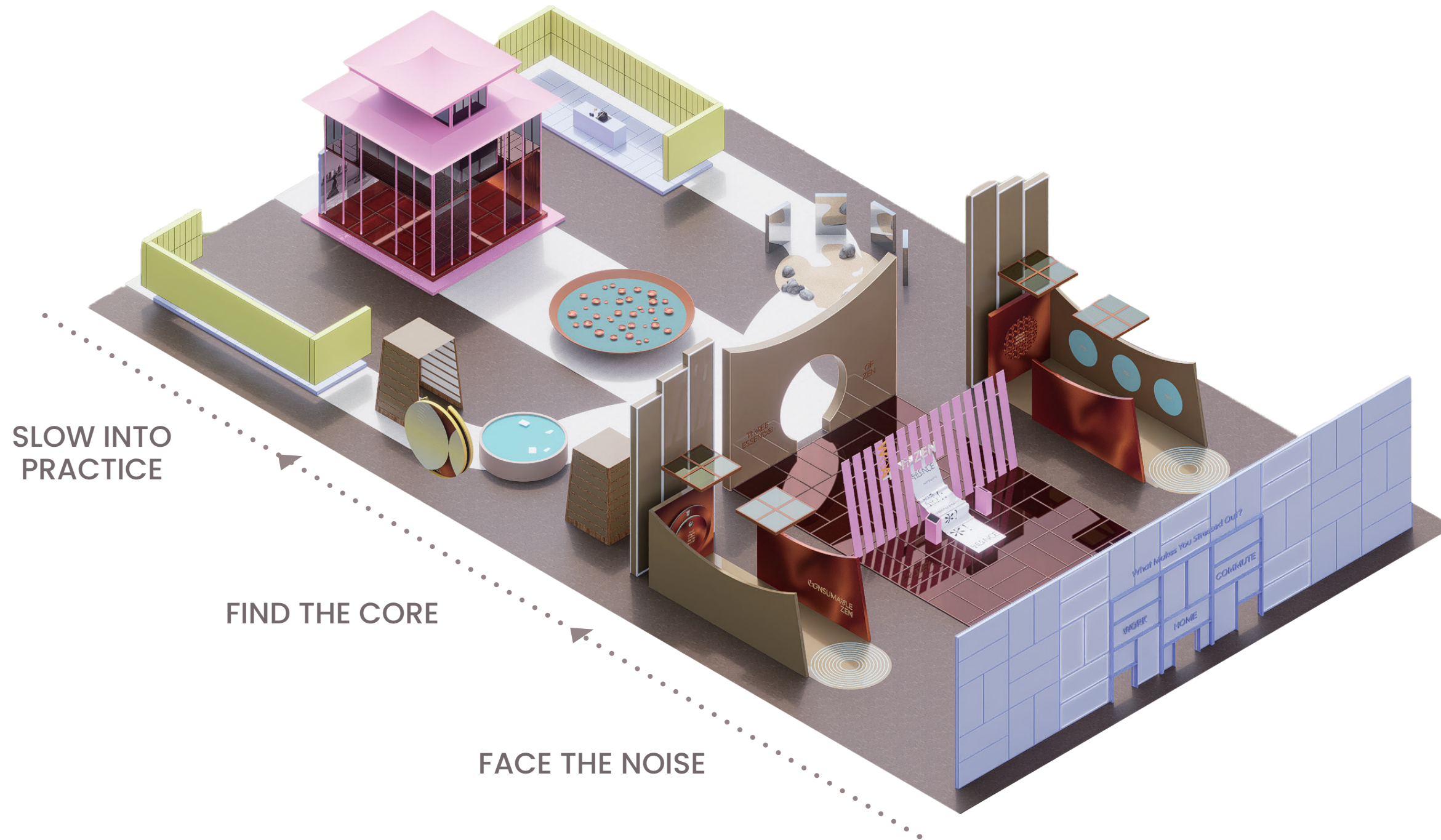

PROJECT
THROUGH SAMBARA

DRAWN BY
SUJIN HWANG

SITE
60 WALL STREET
ARTRIUM, NYC

CLIENT
BLOOMBERG
PHILANTHROPIES

NOTES
DRAWINGS FOR
DESIGN INTENT ONLY

KEY PLAN

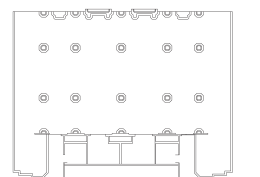

DATE
DEC 12, 2025

SCALE
AS NOTED

DRAWING
OVERVIEW

DRAWING NO.
EX.01.11

THROUGH SAMSARA

At the entrance, visitors encounter three doors — HOME, WORK, and COMMUTE. Each one poses a simple but grounding question: “What is stressing you right now?” This moment invites visitors to pause and recognize the tensions that shape their everyday lives.

The entrance is intentionally low, prompting visitors to gently bow their bodies as they step inside. This subtle gesture echoes a key moment in Zen — a brief act of lowering one’s tension and roles before entering a new state of presence. Whichever door they choose, the paths soon converge into a single space. Here, the journey of Zen quietly begins.

SUJIN HWANG



PROJECT
THROUGH SAMSARA

DRAWN BY
SUJIN HWANG

SITE
60 WALL STREET
ARTRIUUM, NYC

CLIENT
BLOOMBERG
PHILANTHROPIES

NOTES
DRAWINGS FOR
DESIGN INTENT ONLY

KEY PLAN

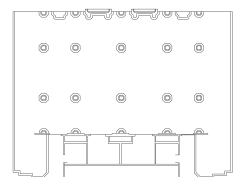

DATE
DEC 12, 2025

SCALE
AS NOTED

DRAWING
RENDERINGS

DRAWING NO.
EX.01.12

THROUGH SAMSARA



SUJIN HWANG



PROJECT
THROUGH SAMSARA

DRAWN BY
SUJIN HWANG

SITE
60 WALL STREET
ARTRIUM, NYC

CLIENT
BLOOMBERG
PHILANTHROPIES

NOTES
DRAWINGS FOR
DESIGN INTENT ONLY

KEY PLAN

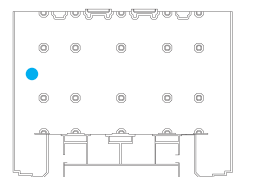

DATE
DEC 12, 2025

SCALE
AS NOTED

DRAWING
RENDERINGS

DRAWING NO.
EX.01.13

THROUGH SAMBARA



FIT School of
Graduate Studies
Exhibition and
Experience Design

SUJIN HWANG



PROJECT
THROUGH SAMBARA

DRAWN BY
SUJIN HWANG

SITE
60 WALL STREET
ARTRIUM, NYC

CLIENT
BLOOMBERG
PHILANTHROPIES

NOTES
DRAWINGS FOR
DESIGN INTENT ONLY

KEY PLAN

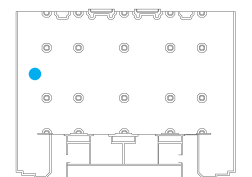

DATE
DEC 12, 2025

SCALE
AS NOTED

DRAWING
RENDERINGS

DRAWING NO.
EX.01.14

WHAT IS ZEN TO YOU

This section begins by asking visitors a simple but open question: “What is Zen?” Responses typed into the kiosk are printed in real time on a large-format roll printer, unfolding as an ever-growing stream of collective thoughts.

Most of the submitted words appear as adjectives, impressions, and feelings — revealing how visitors tend to understand Zen not as a practice, but as a sensory and emotional experience.

As these thoughts accumulate on the continuous roll of paper, they form a visual landscape of how Zen is perceived today, allowing visitors to encounter the many different ways people imagine its meaning.



PROJECT
THROUGH SAMSARA

DRAWN BY
SUJIN HWANG

SITE
60 WALL STREET
ARTRIUUM, NYC

CLIENT
BLOOMBERG
PHILANTHROPIES

NOTES
DRAWINGS FOR
DESIGN INTENT ONLY

KEY PLAN

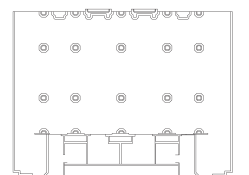

DATE
DEC 12, 2025

SCALE
AS NOTED

DRAWING
RENDERINGS

DRAWING NO.
EX.01.15

WHAT IS ZEN TO YOU



FIT School of
Graduate Studies
Exhibition and
Experience Design

SUJIN HWANG



PROJECT
THROUGH SAMBARA

DRAWN BY
SUJIN HWANG

SITE
60 WALL STREET
ARTRIUM, NYC

CLIENT
BLOOMBERG
PHILANTHROPIES

NOTES
DRAWINGS FOR
DESIGN INTENT ONLY

KEY PLAN

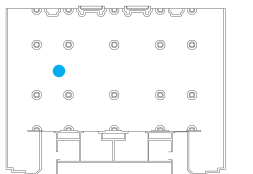

DATE
DEC 12, 2025

SCALE
AS NOTED

DRAWING
RENDERINGS

DRAWING NO.
EX.01.16

WHAT IS ZEN TO YOU



FIT School of
Graduate Studies
Exhibition and
Experience Design

SUJIN HWANG



PROJECT
THROUGH SAMSARA

DRAWN BY
SUJIN HWANG

SITE
60 WALL STREET
ARTRIUM, NYC

CLIENT
BLOOMBERG
PHILANTHROPIES

NOTES
DRAWINGS FOR
DESIGN INTENT ONLY

KEY PLAN

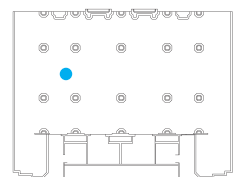

DATE
DEC 12, 2025

SCALE
AS NOTED

DRAWING
RENDERINGS

DRAWING NO.
EX.01.17

CONSUMABLE ZEN

Consumable Zen is the packaged, aesthetic version of Zen—candles, diffusers, stones, and calming words. It offers quick relief and a “Zen-like” feeling, but stays on the surface. It soothes for a moment without leading to real practice or change. It is the look of peace, not the work of peace.

SUJIN HWANG



PROJECT
THROUGH SAMSARA

DRAWN BY
SUJIN HWANG

SITE
60 WALL STREET
ARTRIUUM, NYC

CLIENT
BLOOMBERG
PHILANTHROPIES

NOTES
DRAWINGS FOR
DESIGN INTENT ONLY

KEY PLAN

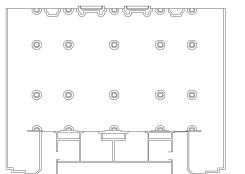

DATE
DEC 12, 2025

SCALE
AS NOTED

DRAWING
RENDERINGS

DRAWING NO.
EX.01.18

CONSUMABLE ZEN

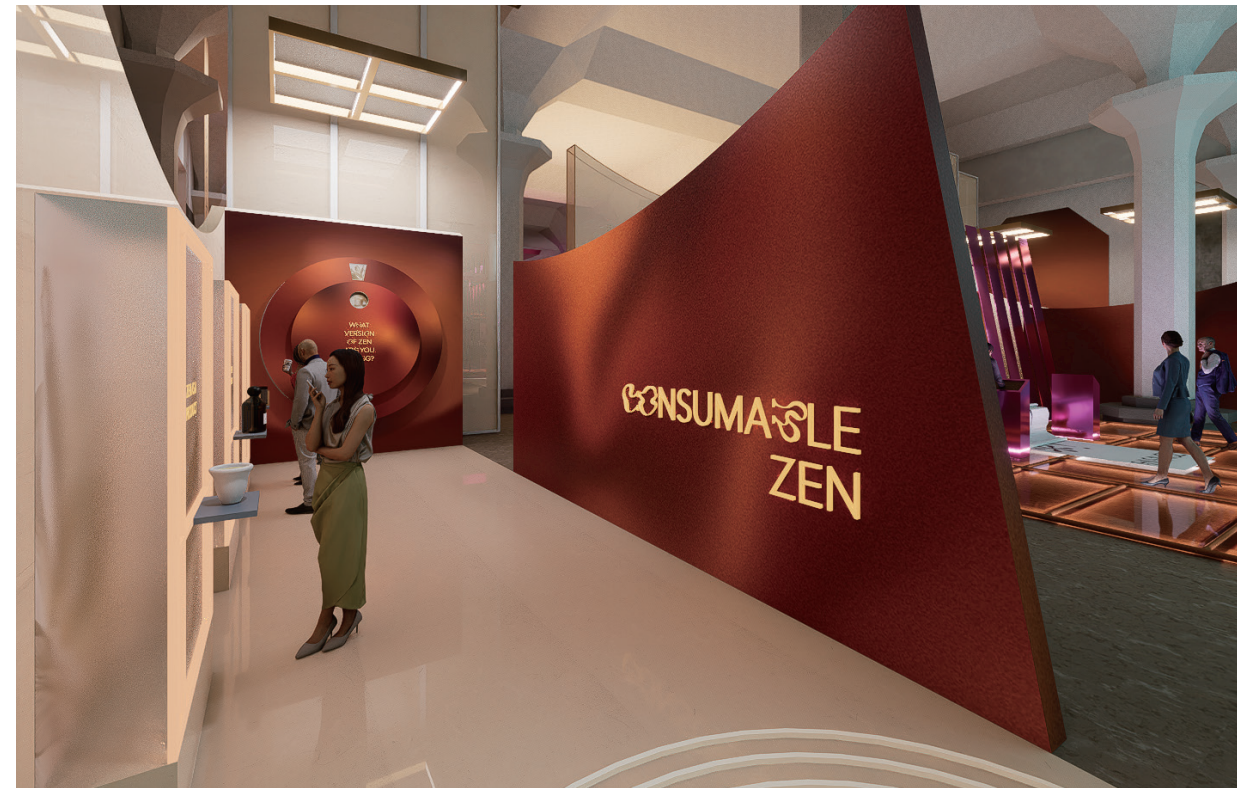

FIT School of Graduate Studies
Exhibition and Experience Design

SUJIN HWANG



PROJECT
THROUGH SAMSARA

DRAWN BY
SUJIN HWANG

SITE
60 WALL STREET
ARTRIUM, NYC

CLIENT
BLOOMBERG
PHILANTHROPIES

NOTES
DRAWINGS FOR
DESIGN INTENT ONLY

KEY PLAN

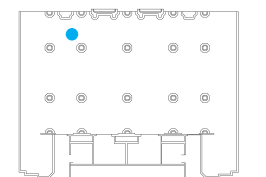

DATE
DEC 12, 2025

SCALE
AS NOTED

DRAWING
RENDERINGS

DRAWING NO.
EX.01.19

CONSUMABLE ZEN



FIT School of
Graduate Studies
Exhibition and
Experience Design

SUJIN HWANG



PROJECT
THROUGH SAMBARA

DRAWN BY
SUJIN HWANG

SITE
60 WALL STREET
ARTRIUM, NYC

CLIENT
BLOOMBERG
PHILANTHROPIES

NOTES
DRAWINGS FOR
DESIGN INTENT ONLY

KEY PLAN

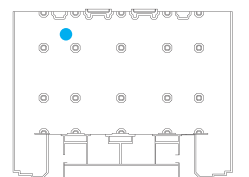

DATE
DEC 12, 2025

SCALE
AS NOTED

DRAWING
RENDERINGS

DRAWING NO.
EX.01.20

AUTEHNTIC ZEN

This section reveals the original nature of Zen with quiet subtlety. Through a translucent surface, the faint silhouettes of people in seated meditation appear, prompting visitors to momentarily wonder, “Is Zen simply meditation?”

Along one wall, a slowly rotating Zen Garden installation continuously forms and dissolves lines through the movement of small spheres. These shifting patterns—appearing, disappearing, and reforming—demonstrate that Zen is not an image, but a process of ongoing practice and attentive observation.

As visitors watch this gentle motion, Zen is reframed not as comfort or ambience, but as an act of looking, repeating, and being present.

SUJIN HWANG



PROJECT
THROUGH SAMSARA

DRAWN BY
SUJIN HWANG

SITE
60 WALL STREET
ARTRIUUM, NYC

CLIENT
BLOOMBERG
PHILANTHROPIES

NOTES
DRAWINGS FOR
DESIGN INTENT ONLY

KEY PLAN

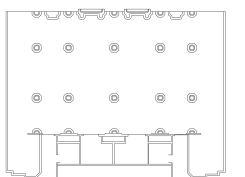

DATE
DEC 12, 2025

SCALE
AS NOTED

DRAWING
RENDERINGS

DRAWING NO.
EX.01.21

AUTEHNTIC ZEN



FIT School of
Graduate Studies
Exhibition and
Experience Design

SUJIN HWANG



PROJECT
THROUGH SAMSARA

DRAWN BY
SUJIN HWANG

SITE
60 WALL STREET
ARTRIUM, NYC

CLIENT
BLOOMBERG
PHILANTHROPIES

NOTES
DRAWINGS FOR
DESIGN INTENT ONLY

KEY PLAN

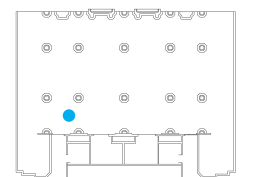

DATE
DEC 12, 2025

SCALE
AS NOTED

DRAWING
RENDERINGS

DRAWING NO.
EX.01.22

AUTEHNTIC ZEN



FIT School of
Graduate Studies
Exhibition and
Experience Design

SUJIN HWANG



PROJECT
THROUGH SAMBARA

DRAWN BY
SUJIN HWANG

SITE
60 WALL STREET
ARTRIUM, NYC

CLIENT
BLOOMBERG
PHILANTHROPIES

NOTES
DRAWINGS FOR
DESIGN INTENT ONLY

KEY PLAN

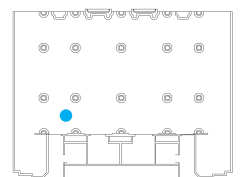

DATE
DEC 12, 2025

SCALE
AS NOTED

DRAWING
RENDERINGS

DRAWING NO.
EX.01.23

THREE ESSENCE OF ZEN

This area introduces the three essences of Zen, marking the moment when visitors begin to truly enter its world.

Through the translucent surface, faint hints of light, movement, and shifting silhouettes appear, creating a quiet sense of anticipation for what lies ahead.

From a distance, the soft resonance of a singing bowl,
the gentle sound of water,
and subtle vibrations in the air begin to emerge,
guiding visitors into a slower, more attentive rhythm.

SUJIN HWANG



PROJECT
THROUGH SAMSARA

DRAWN BY
SUJIN HWANG

SITE
60 WALL STREET
ARTRIUUM, NYC

CLIENT
BLOOMBERG
PHILANTHROPIES

NOTES
DRAWINGS FOR
DESIGN INTENT ONLY

KEY PLAN

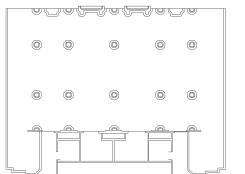

DATE
DEC 12, 2025

SCALE
AS NOTED

DRAWING
RENDERINGS

DRAWING NO.
EX.01.24

THREE ESSENCE OF ZEN



FIT School of
Graduate Studies
Exhibition and
Experience Design

SUJIN HWANG



PROJECT
THROUGH SAMBARA

DRAWN BY
SUJIN HWANG

SITE
60 WALL STREET
ARTRIUM, NYC

CLIENT
BLOOMBERG
PHILANTHROPIES

NOTES
DRAWINGS FOR
DESIGN INTENT ONLY

KEY PLAN

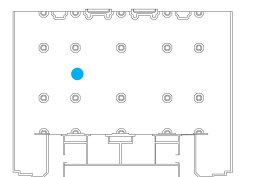

DATE
DEC 12, 2025

SCALE
AS NOTED

DRAWING
RENDERINGS

DRAWING NO.
EX.01.25

NOTHING STAYS

In this section, multiple singing bowls move and vibrate, producing ever-changing sounds and waves with each subtle shift.

No tone returns once it fades, and every rhythm that forms dissolves into another, never repeating in the same way again.

This continuous transformation quietly embodies the Zen teaching of impermanence. Nothing lingers, and no resonance remains fixed — inviting visitors to understand impermanence through sound itself.

SUJIN HWANG



PROJECT
THROUGH SAMSARA

DRAWN BY
SUJIN HWANG

SITE
60 WALL STREET
ARTRIUUM, NYC

CLIENT
BLOOMBERG
PHILANTHROPIES

NOTES
DRAWINGS FOR
DESIGN INTENT ONLY

KEY PLAN

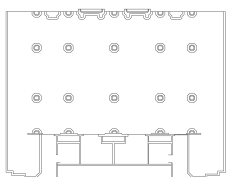

DATE
DEC 12, 2025

SCALE
AS NOTED

DRAWING
RENDERINGS

DRAWING NO.
EX.01.26

NOTHING STAYS



FIT School of
Graduate Studies
Exhibition and
Experience Design

SUJIN HWANG



PROJECT
THROUGH SAMSARA

DRAWN BY
SUJIN HWANG

SITE
60 WALL STREET
ARTRIUM, NYC

CLIENT
BLOOMBERG
PHILANTHROPIES

NOTES
DRAWINGS FOR
DESIGN INTENT ONLY

KEY PLAN

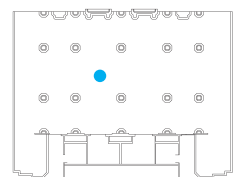

DATE
DEC 12, 2025

SCALE
AS NOTED

DRAWING
RENDERINGS

DRAWING NO.
EX.01.27

NOTHING STAYS

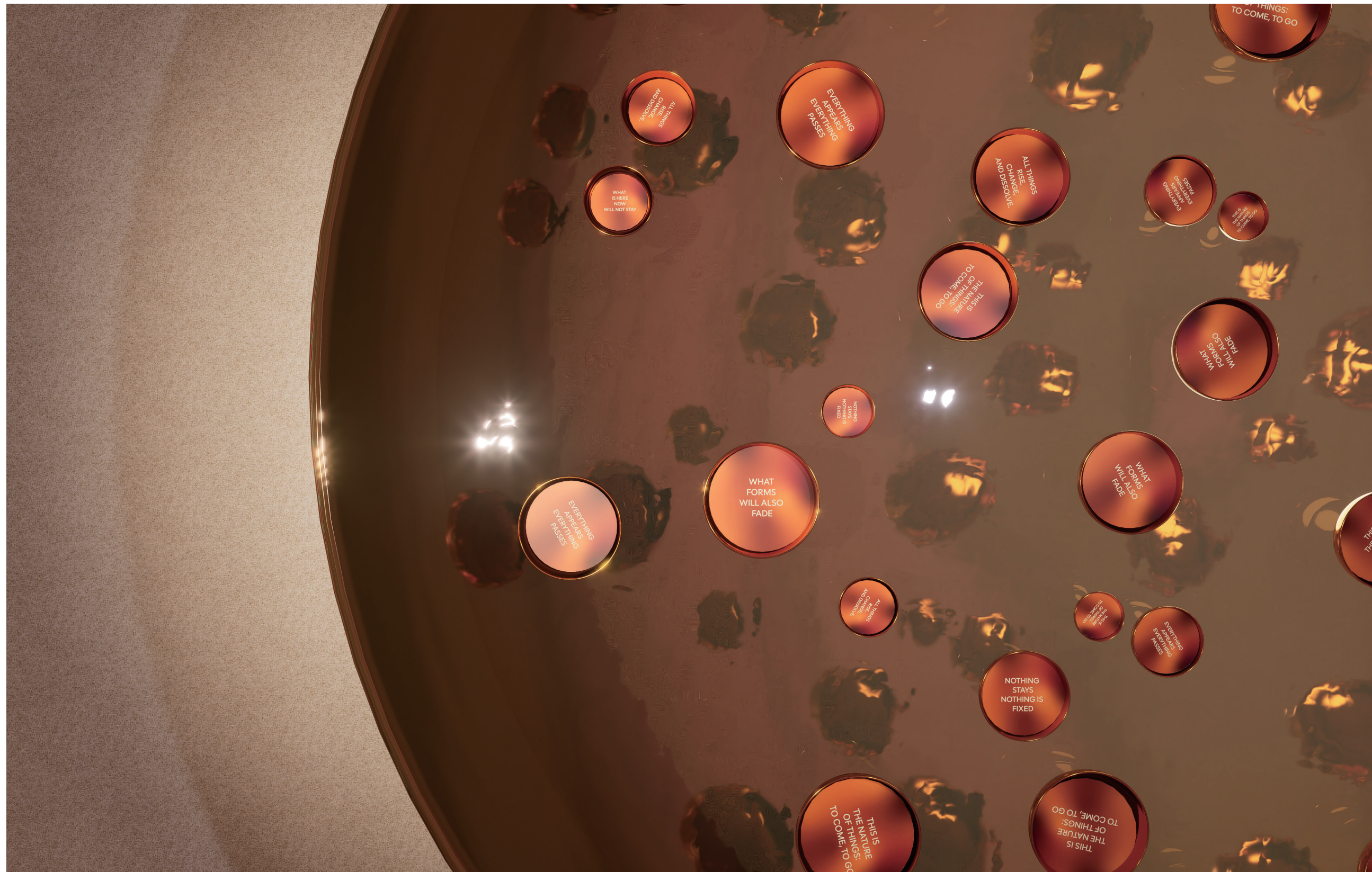

SUJIN HWANG



PROJECT
THROUGH SAMSARA

DRAWN BY
SUJIN HWANG

SITE
60 WALL STREET
ARTRIUM, NYC

CLIENT
BLOOMBERG
PHILANTHROPIES

NOTES
DRAWINGS FOR
DESIGN INTENT ONLY

KEY PLAN

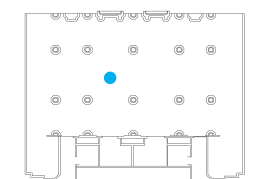

DATE
DEC 12, 2025

SCALE
AS NOTED

DRAWING
RENDERINGS

DRAWING NO.
EX.01.28

NOTHING HOLDS

In this section, visitors write their attachments on pieces of water-soluble paper. As the paper sinks into the water, the words begin to blur, dissolve, and eventually disappear entirely.

Watching the form fade shows that attachment does not dissolve by holding on, but only in the moment of letting go.

The gentle disintegration of the paper conveys the Zen teaching of non-attachment through experience rather than explanation — a quiet reminder that release, not grasping, is what creates lightness.

SUJIN HWANG



PROJECT
THROUGH SAMSARA

DRAWN BY
SUJIN HWANG

SITE
60 WALL STREET
ARTRIUUM, NYC

CLIENT
BLOOMBERG
PHILANTHROPIES

NOTES
DRAWINGS FOR
DESIGN INTENT ONLY

KEY PLAN

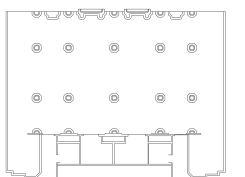

DATE
DEC 12, 2025

SCALE
AS NOTED

DRAWING
RENDERINGS

DRAWING NO.
EX.01.29

NOTHING HOLDS



FIT School of
Graduate Studies
Exhibition and
Experience Design

SUJIN HWANG



PROJECT
THROUGH SAMBARA

DRAWN BY
SUJIN HWANG

SITE
60 WALL STREET
ARTRIUM, NYC

CLIENT
BLOOMBERG
PHILANTHROPIES

NOTES
DRAWINGS FOR
DESIGN INTENT ONLY

KEY PLAN

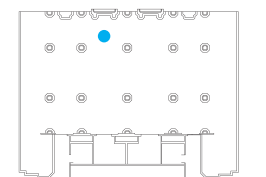

DATE
DEC 12, 2025

SCALE
AS NOTED

DRAWING
RENDERINGS

DRAWING NO.
EX.01.30

NOTHING HOLDS



FIT School of
Graduate Studies
Exhibition and
Experience Design

SUJIN HWANG



PROJECT
THROUGH SAMBARA

DRAWN BY
SUJIN HWANG

SITE
60 WALL STREET
ARTRIUM, NYC

CLIENT
BLOOMBERG
PHILANTHROPIES

NOTES
DRAWINGS FOR
DESIGN INTENT ONLY

KEY PLAN

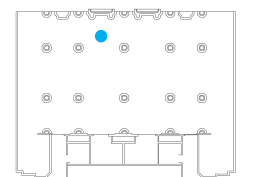

DATE
DEC 12, 2025

SCALE
AS NOTED

DRAWING
RENDERINGS

DRAWING NO.
EX.01.31

NOTHING STANDS

This section explores the Zen teaching that nothing holds a fixed essence. The display presents stones in different forms—sand, gravel, pebbles, and rock. They appear distinct, yet each form is simply the same stone shaped by context, pressure, and time. Their identity shifts, but their nature remains open and unfixed.

This idea extends to the visitors themselves. An interactive wall asks, “In how many ways do you exist?” Visitors are invited to write the different roles they inhabit in daily life—a colleague, a creator, a friend; a daughter, a mentor, a learner, roles that overlap, change, and never fully define who they are.

As these responses accumulate across the wall, they create a landscape of countless identities coexisting at once. Through this collective display, the space reveals that we are not a single, fixed self, but beings who continually shift according to relationship, moment, and circumstance.

SUJIN HWANG



PROJECT
THROUGH SAMSARA

DRAWN BY
SUJIN HWANG

SITE
60 WALL STREET
ARTRIUUM, NYC

CLIENT
BLOOMBERG
PHILANTHROPIES

NOTES
DRAWINGS FOR
DESIGN INTENT ONLY

KEY PLAN

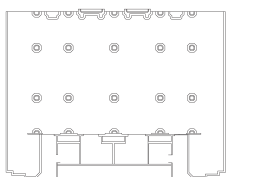

DATE
DEC 12, 2025

SCALE
AS NOTED

DRAWING
RENDERINGS

DRAWING NO.
EX.01.32

NOTHING STANDS



SUJIN HWANG



PROJECT
THROUGH SAMSARA

DRAWN BY
SUJIN HWANG

SITE
60 WALL STREET
ARTRIUM, NYC

CLIENT
BLOOMBERG
PHILANTHROPIES

NOTES
DRAWINGS FOR
DESIGN INTENT ONLY

KEY PLAN

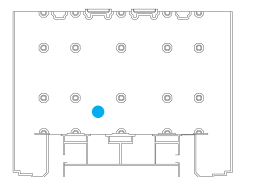

DATE
DEC 12, 2025

SCALE
AS NOTED

DRAWING
RENDERINGS

DRAWING NO.
EX.01.33

BEGIN HERE

In this space, visitors encounter illustrations of people meditating across familiar New York settings—

Central Park, office desks, living rooms, riversides, and other everyday places. These images reveal that Zen is not confined to a temple or a retreat, but can unfold quietly wherever breath and attention meet.

By placing meditation within the city's ordinary scenes, the installation reframes Zen as a practice woven into daily life—a stillness that can arise amid movement, noise, and routine. It invites visitors to see their own surroundings as potential places of practice, suggesting that the city itself can become a ground for presence.

As an extension of this idea, the exhibition includes collaborations with various Zen centers across New York.

Trained instructors offer guided sittings, allowing visitors to experience authentic Zen meditation within the context of the installation.

SUJIN HWANG



PROJECT
THROUGH SAMSARA

DRAWN BY
SUJIN HWANG

SITE
60 WALL STREET
ARTRIUUM, NYC

CLIENT
BLOOMBERG
PHILANTHROPIES

NOTES
DRAWINGS FOR
DESIGN INTENT ONLY

KEY PLAN

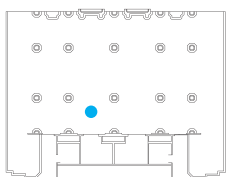

DATE
DEC 12, 2025

SCALE
AS NOTED

DRAWING
RENDERINGS

DRAWING NO.
EX.01.34

BEGIN HERE



FIT School of
Graduate Studies
Exhibition and
Experience Design

SUJIN HWANG



PROJECT
THROUGH SAMBARA

DRAWN BY
SUJIN HWANG

SITE
60 WALL STREET
ARTRIUM, NYC

CLIENT
BLOOMBERG
PHILANTHROPIES

NOTES
DRAWINGS FOR
DESIGN INTENT ONLY

KEY PLAN

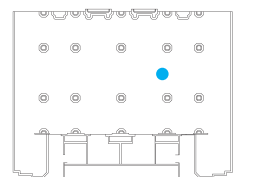

DATE
DEC 12, 2025

SCALE
AS NOTED

DRAWING
RENDERINGS

DRAWING NO.
EX.01.35

BEGIN HERE



FIT School of
Graduate Studies
Exhibition and
Experience Design

SUJIN HWANG



PROJECT
THROUGH SAMSARA

DRAWN BY
SUJIN HWANG

SITE
60 WALL STREET
ARTRIUM, NYC

CLIENT
BLOOMBERG
PHILANTHROPIES

NOTES
DRAWINGS FOR
DESIGN INTENT ONLY

KEY PLAN

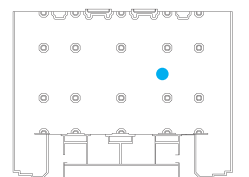

DATE
DEC 12, 2025

SCALE
AS NOTED

DRAWING
RENDERINGS

DRAWING NO.
EX.01.36

BEGIN HERE



SUJIN HWANG



PROJECT
THROUGH SAMBARA

DRAWN BY
SUJIN HWANG

SITE
60 WALL STREET
ARTRIUM, NYC

CLIENT
BLOOMBERG
PHILANTHROPIES

NOTES
DRAWINGS FOR
DESIGN INTENT ONLY

KEY PLAN

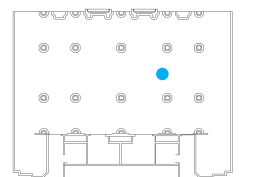

DATE
DEC 12, 2025

SCALE
AS NOTED

DRAWING
RENDERINGS

DRAWING NO.
EX.01.37

CALM IN YOUR HANDS

This space reveals tea drinking as more than a simple act — it becomes a practice of staying with the senses. Warmth, aroma, and the movement of tea down the throat invite visitors to slow their pace and settle into the present moment.

In Zen, drinking tea is a way of learning stillness and presence. Without doing anything extra, the act of tasting becomes a brief pause where the mind gently quiets.

SUJIN HWANG



PROJECT
THROUGH SAMSARA

DRAWN BY
SUJIN HWANG

SITE
60 WALL STREET
ARTRIUUM, NYC

CLIENT
BLOOMBERG
PHILANTHROPIES

NOTES
DRAWINGS FOR
DESIGN INTENT ONLY

KEY PLAN

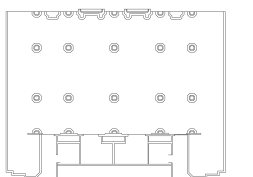

DATE
DEC 12, 2025

SCALE
AS NOTED

DRAWING
RENDERINGS

DRAWING NO.
EX.01.38

CALM IN YOUR HANDS

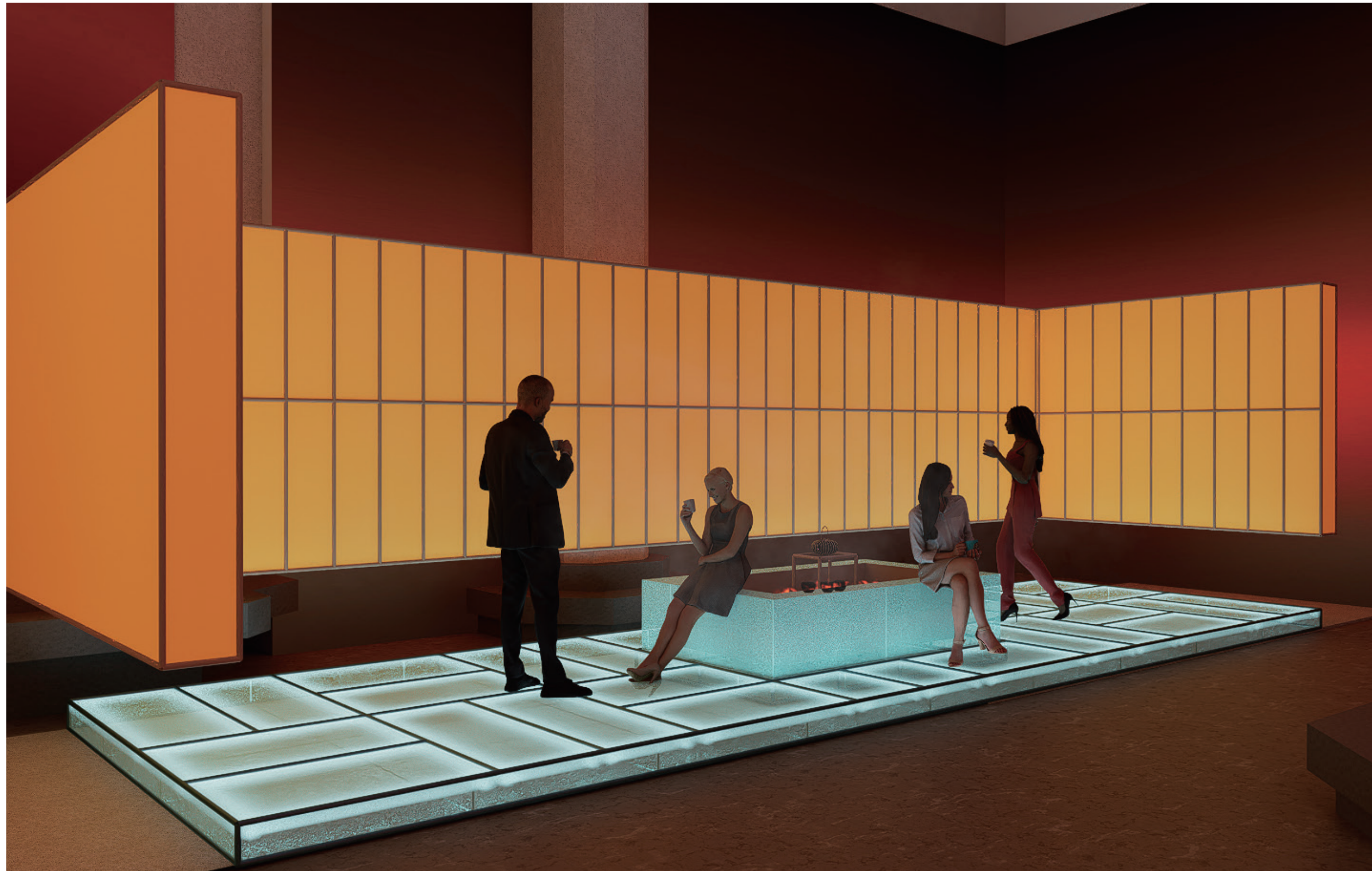

FIT School of
Graduate Studies
Exhibition and
Experience Design

SUJIN HWANG



PROJECT
THROUGH SAMSARA

DRAWN BY
SUJIN HWANG

SITE
60 WALL STREET
ARTRIUUM, NYC

CLIENT
BLOOMBERG
PHILANTHROPIES

NOTES
DRAWINGS FOR
DESIGN INTENT ONLY

KEY PLAN

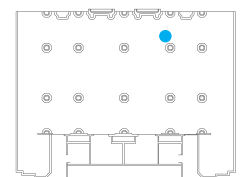

DATE
DEC 12, 2025

SCALE
AS NOTED

DRAWING
RENDERINGS

DRAWING NO.
EX.01.39

THE MOMENT THAT BREATHES

Here, the entire process of making tea becomes a form of practice. Heating the water, sensing the aroma, pouring, waiting — each step embodies Zen’s emphasis on attentive observation and deliberate repetition.

Nothing is rushed; the tea unfolds at its own rhythm, arriving only when the moment is right.

The process illustrates a core Zen insight: the practice is found not in the outcome, but in the care of each step. It is a reminder that precision, patience, and presence are themselves expressions of Zen.



PROJECT
THROUGH SAMSARA

DRAWN BY
SUJIN HWANG

SITE
60 WALL STREET
ARTRIUUM, NYC

CLIENT
BLOOMBERG
PHILANTHROPIES

NOTES
DRAWINGS FOR
DESIGN INTENT ONLY

KEY PLAN

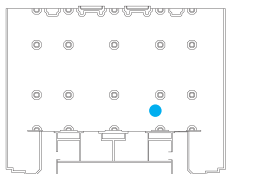

DATE
DEC 12, 2025

SCALE
AS NOTED

DRAWING
RENDERINGS

DRAWING NO.
EX.01.40

THE MOMENT THAT BREATHES

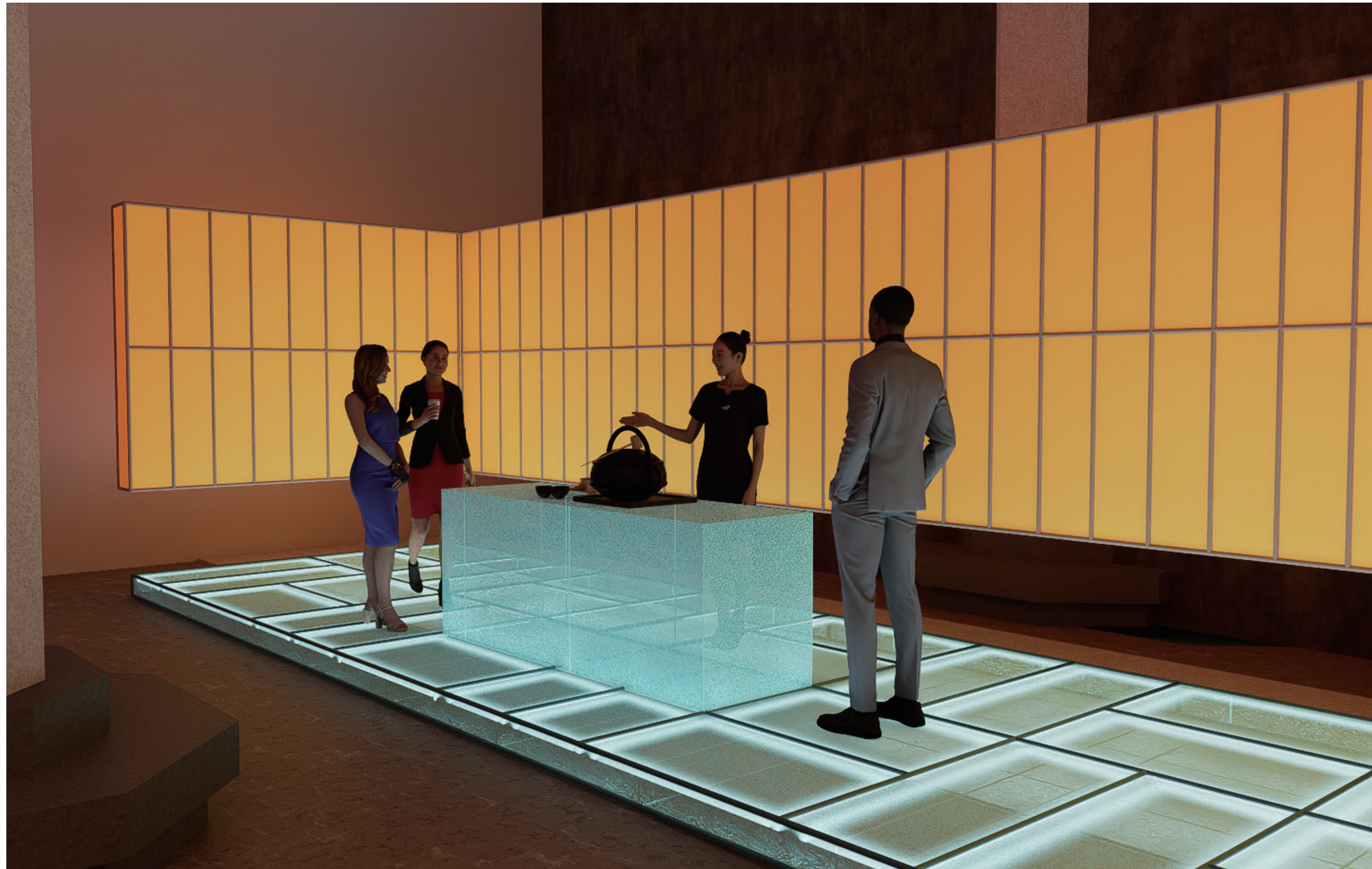

FIT School of
Graduate Studies
Exhibition and
Experience Design

SUJIN HWANG



PROJECT
THROUGH SAMBARA

DRAWN BY
SUJIN HWANG

SITE
60 WALL STREET
ARTRIUM, NYC

CLIENT
BLOOMBERG
PHILANTHROPIES

NOTES
DRAWINGS FOR
DESIGN INTENT ONLY

KEY PLAN

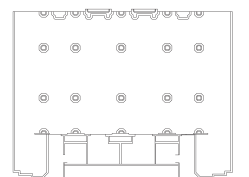

DATE
DEC 12, 2025

SCALE
AS NOTED

DRAWING
RENDERINGS

DRAWING NO.
EX.01.41

SCHEDULES & LISTS

SUJIN HWANG



PROJECT
THROUGH SAMSARA

DRAWN BY
SUJIN HWANG

SITE
60 WALL STREET
ARTRIUM, NYC

CLIENT
BLOOMBERG
PHILANTHROPIES

NOTES
DRAWINGS FOR
DESIGN INTENT ONLY

KEY PLAN

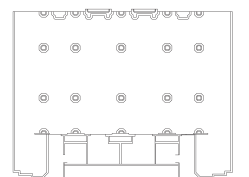

DATE
DEC 12, 2025

SCALE
AS NOTED

DRAWING
SCHEDULES & LISTS

DRAWING NO.
EX.02.01

GRAPHIC SCHEDULE

AREA INTRO	GRAPHIC TYPE	DESCRIPTION	CONTENT GRAPHIC	GRAPHIC TYPE	DESCRIPTION
01A.01.GR01	A	Acrylic Lettering	03A.03.GR01	B	Illuminated Lettering
02A.01.GR01	A	Acrylic Lettering	03A.03.GR02	B	Illuminated Lettering
02A.02.GR01	A	Acrylic Lettering	03A.03.GR03	B	Illuminated Lettering
02A.02.GR02	A	Acrylic Lettering	04A.03.GR01	B	Illuminated Lettering
02A.01.GR02	E	Fabric Graphic	04A.03.GR02	B	Illuminated Lettering
05A.03.GR01	E	Fabric Graphic	04A.03.GR03	B	Illuminated Lettering
05A.03.GR02	E	Fabric Graphic	06A.01.GR01	D	Insert Graphic
06A.02.GR01	E	Fabric Graphic	07A.01.GR01	H	Poster Graphic
06A.02.GR02	E	Fabric Graphic	07A.01.GR02	H	Poster Graphic
07A.02.GR01	E	Fabric Graphic	07A.01.GR03	H	Poster Graphic
07A.02.GR02	E	Fabric Graphic	07A.01.GR04	H	Poster Graphic
03A.01.GR01	F	Fitted Panel Graphic	07A.01.GR05	H	Poster Graphic
04A.01.GR01	F	Fitted Panel Graphic	08A.01.GR01	H	Poster Graphic
05A.02.GR01	F	Fitted Panel Graphic	08A.01.GR02	H	Poster Graphic
05A.02.GR02	F	Fitted Panel Graphic	08A.01.GR03	H	Poster Graphic
			10A.01.GR01	H	Poster Graphic
			10A.01.GR02	H	Poster Graphic
			10A.01.GR03	H	Poster Graphic



SUJIN HWANG



PROJECT
THROUGH SAMSARA

DRAWN BY
SUJIN HWANG

SITE
60 WALL STREET
ARTRIUUM, NYC

CLIENT
BLOOMBERG
PHILANTHROPIES

NOTES
DRAWINGS FOR
DESIGN INTENT ONLY

KEY PLAN

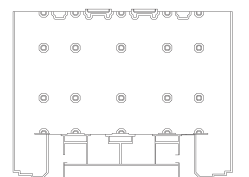

DATE
DEC 12, 2025

SCALE
AS NOTED

DRAWING
SCHEDULES

DRAWING NO.
EX.02.02

GRAPHIC SCHEDULE

CONTENT GRAPHIC	GRAPHIC TYPE	DESCRIPTION
09A.01.GR01	G	Wall Graphic

KINETIC GRAPHICS	GRAPHIC TYPE	DESCRIPTION
03A.02.GR01	C	Rotating Graphic
04A.02.GR01	C	Rotating Graphic
05A.01.GR01	C	Rotating Graphic

MATERIAL SCHEDULE

MATERIAL	TAG	DESCRIPTION
ACRYLIC	AC01	1/2" FROSTED TRANSLUCENT ACRYLIC
	AC02	3/8" CLEAR ACRYLIC,
	AC03	1/2" LIGHT-DIFFUSING ACRYLIC (LED READY)

FABRIC	FB01	STRETCH FABRIC PANEL
	FB02	SEMI-SHEER WOVEN FABRIC
MIRROR	MR01	1/4" MIRROR ACRYLIC (LIGHTWEIGHT)
	MR02	1/4" TWO-WAY MIRROR ACRYLIC

AV SCHEDULE

TYPE	TAGS	DESCRIPTION
AV1	AV1.1-AV1.2	27" TOUCHSCREEN
AV2	AV2.1	INTERACTIVE KIOSK

LIGHTING SCHEDULE

TYPE	DESCRIPTION
LT1	LED STRIP INSERTED INTO ACRYLIC PANEL
LT2	CEILING-MOUNTED LINEAR LED, SOFT WASH



PROJECT
THROUGH SAMSARA

DRAWN BY
SUJIN HWANG

SITE
60 WALL STREET
ARTRIUUM, NYC

CLIENT
BLOOMBERG
PHILANTHROPIES

NOTES
DRAWINGS FOR
DESIGN INTENT ONLY

KEY PLAN

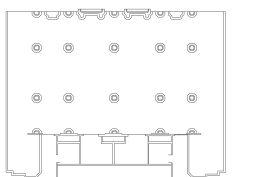

DATE
DEC 12, 2025

SCALE
AS NOTED

DRAWING
SCHEDULES

DRAWING NO.
EX.02.03

GRAPHIC SPECIFICATIONS

GRAPHIC TYPE

DESCRIPTION

A	3D acrylic letters applied to wall or stand. Clean edge finish suitable for primary messaging.
B	Dimensional letters with internal LED light source. Soft, even light spread for key zones.
C	Paper or film graphic wrapped around a rotating core, motorized or manual.
D	Thick paper or chipboard insert placed inside the singing bowl. Removable tactile graphic conveying “letting go” messages.
E	Printed fabric panels or banners. Soft, backlit-friendly surface for atmospheric Zen mood.conveying “letting go” messages.
F	Graphics mounted onto container or structural modules with precise sizing. Produced on PVC, foamboard, or acrylic panels.
G	Large-scale vinyl, UV print, or painted graphics applied directly to wall surfaces.
H	Printed visuals or text panels placed in frames or mounted boards for flexible content display.



SUJIN HWANG



PROJECT
THROUGH SAMSARA

DRAWN BY
SUJIN HWANG

SITE
60 WALL STREET
ARTRIUUM, NYC

CLIENT
BLOOMBERG
PHILANTHROPIES

NOTES
DRAWINGS FOR
DESIGN INTENT ONLY

KEY PLAN

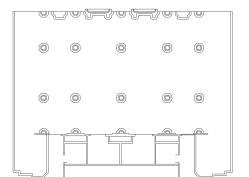

DATE
DEC 12, 2025

SCALE
AS NOTED

DRAWING
SPECIFICTIONS

DRAWING NO.
EX.02.04

PLANS & SECTIONS



SUJIN HWANG



PROJECT
THROUGH SAMSARA

DRAWN BY
SUJIN HWANG

SITE
60 WALL STREET
ARTRIUUM, NYC

CLIENT
BLOOMBERG
PHILANTHROPIES

NOTES
DRAWINGS FOR
DESIGN INTENT ONLY

KEY PLAN

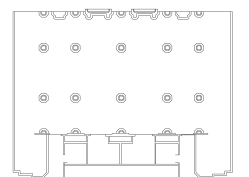

DATE
DEC 12, 2025

SCALE
AS NOTED

DRAWING
PLANS & SECTIONS

DRAWING NO.
EX.03.01

SYMBOLS LIST



SECTION REFERENCE



GRAPHIC TAG



CALL-OUT REFERENCE



MATERIAL TAG



ELEVATION REFERENCE



AV TAG

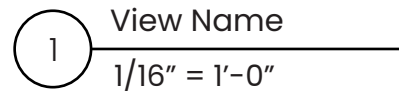

VIEW TITLE

SUJIN HWANG



PROJECT
THROUGH SAMSARA

DRAWN BY
SUJIN HWANG

SITE
60 WALL STREET
ARTRIUM, NYC

CLIENT
BLOOMBERG
PHILANTHROPIES

NOTES
DRAWINGS FOR
DESIGN INTENT ONLY

KEY PLAN

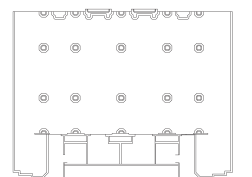

DATE
DEC 12, 2025

SCALE
AS NOTED

DRAWING
SYMBOLS LISTS

DRAWING NO.
EX.03.02

SUJIN HWANG



PROJECT
THROUGH SAMSARA

DRAWN BY
SUJIN HWANG

SITE
60 WALL STREET
ARTRIUUM, NYC

CLIENT
BLOOMBERG
PHILANTHROPIES

NOTES
DRAWINGS FOR
DESIGN INTENT ONLY

KEY PLAN

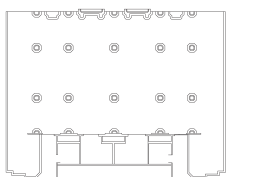

DATE
DEC 12, 2025

SCALE
AS NOTED

DRAWING
GENERAL PLAN

DRAWING NO.
EX.03.03

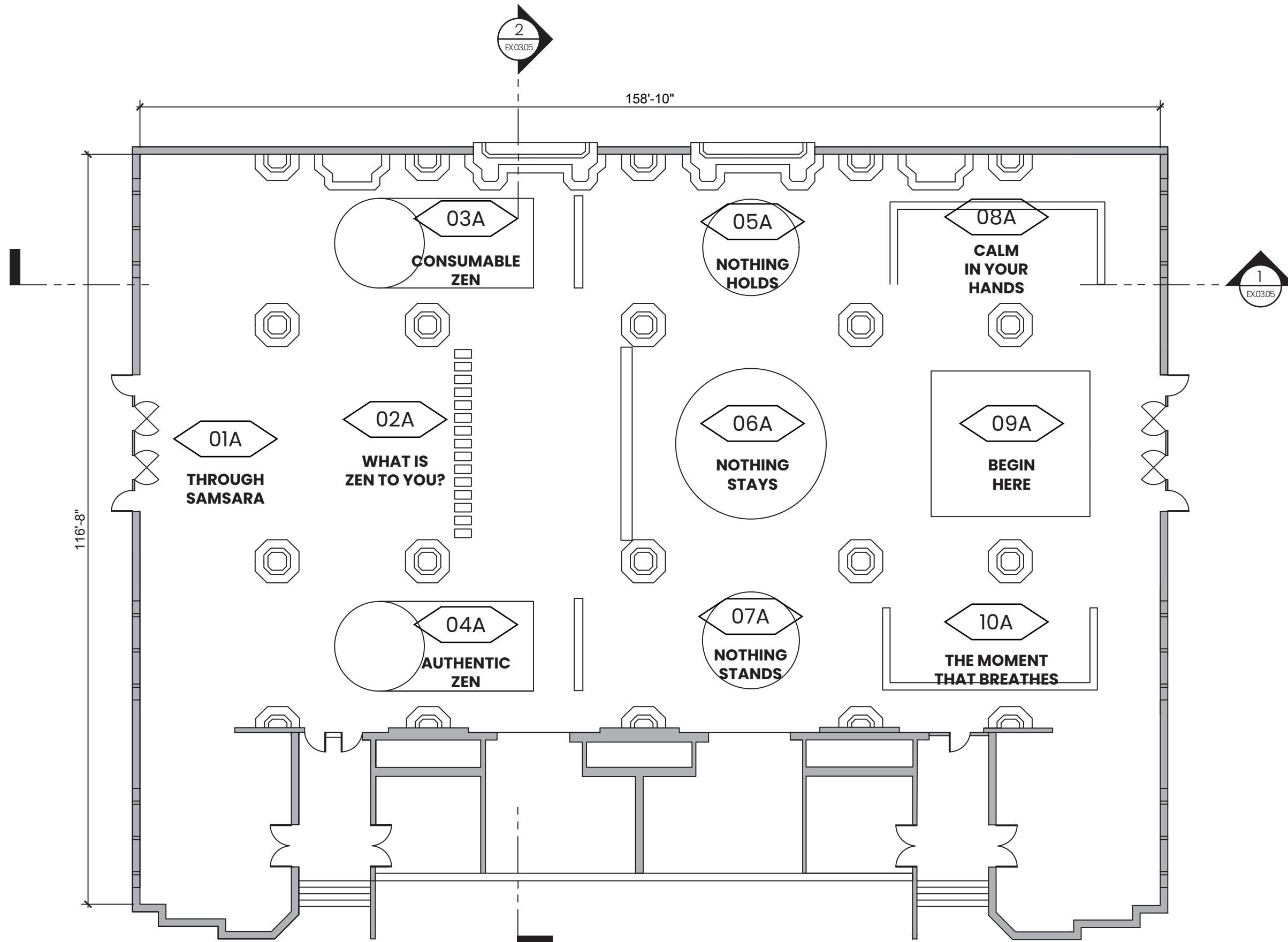

1 General Plan
1/16" = 1'-0"

DIMENSION PLAN

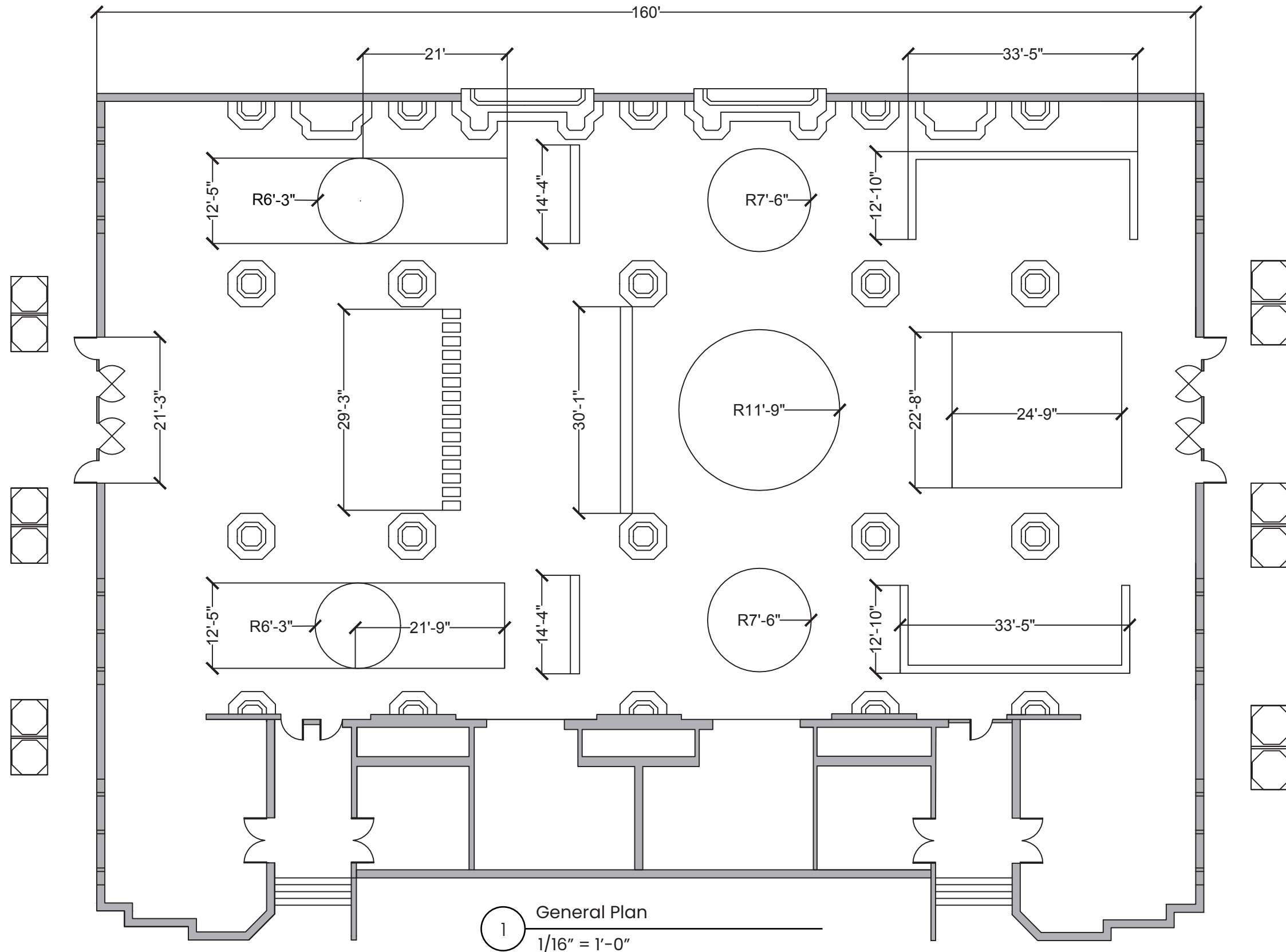

PROJECT
THROUGH SAMSARA

DRAWN BY
SUJIN HWANG

SITE
60 WALL STREET
ARTRIUUM, NYC

CLIENT
BLOOMBERG
PHILANTHROPIES

NOTES
DRAWINGS FOR
DESIGN INTENT ONLY

KEY PLAN

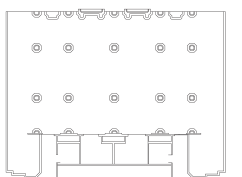

DATE
DEC 12, 2025

SCALE
AS NOTED

DRAWING
DIMENSION PLAN

DRAWING NO.
EX.03.04

GRAPHIC LOCATION PLAN

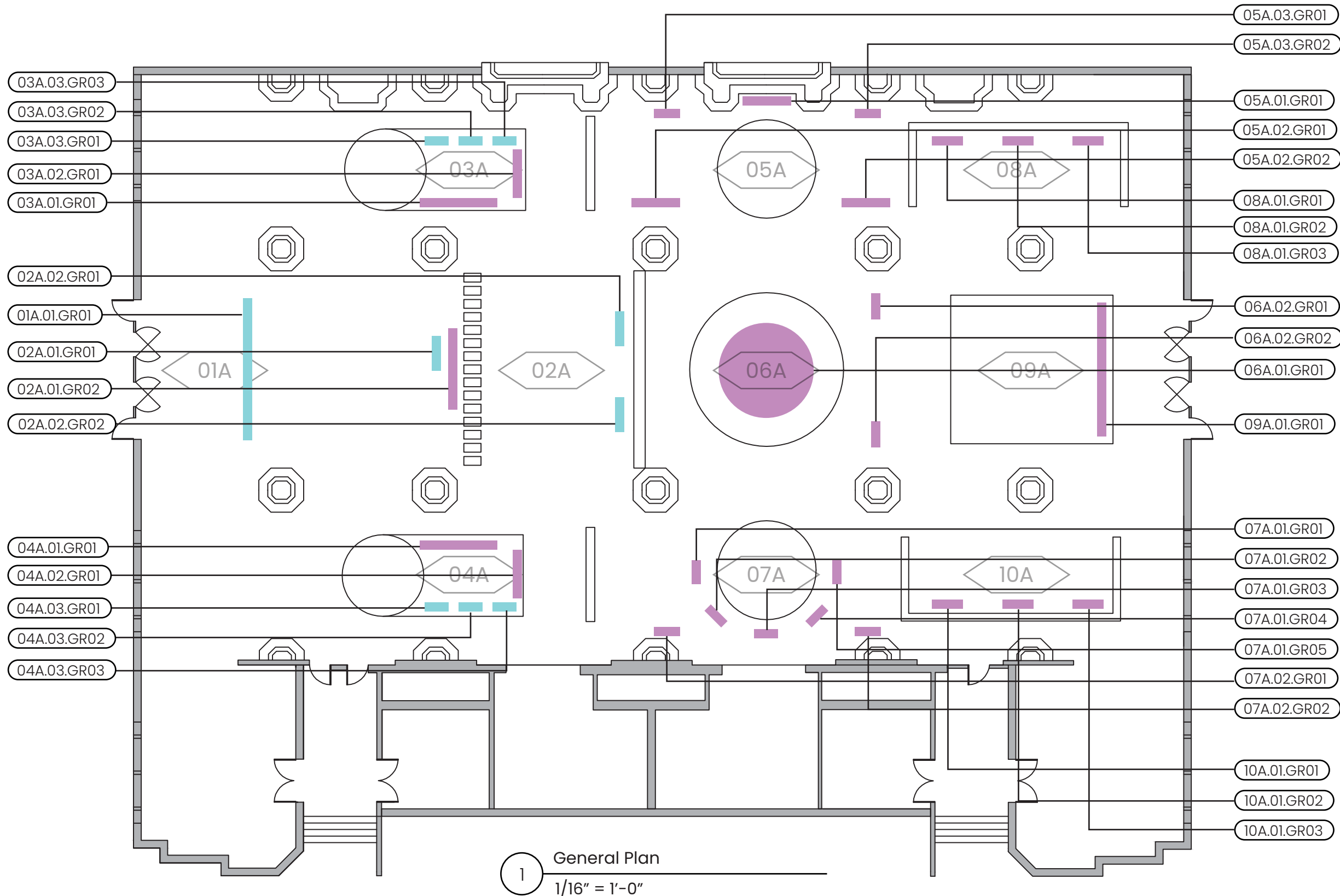

1 General Plan
1/16" = 1'-0"



PROJECT
THROUGH SAMSARA

DRAWN BY
SUJIN HWANG

SITE
60 WALL STREET
ARTRIUUM, NYC

CLIENT
BLOOMBERG
PHILANTHROPIES

NOTES
DRAWINGS FOR
DESIGN INTENT ONLY

KEY PLAN

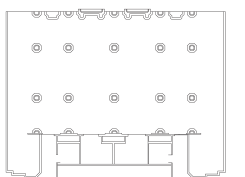

DATE
DEC 12, 2025

SCALE
AS NOTED

DRAWING
GRAPHIC LOCATION
PLAN

DRAWING NO.
EX.03.05

OVERALL SECTIONS

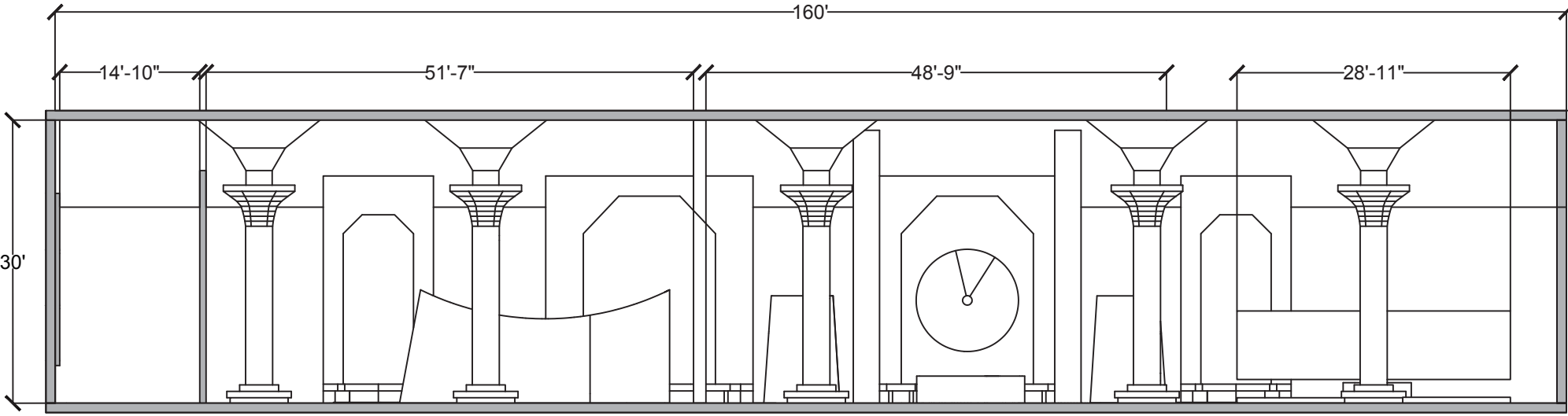

1 Overall Section A
1/16" = 1'-0"

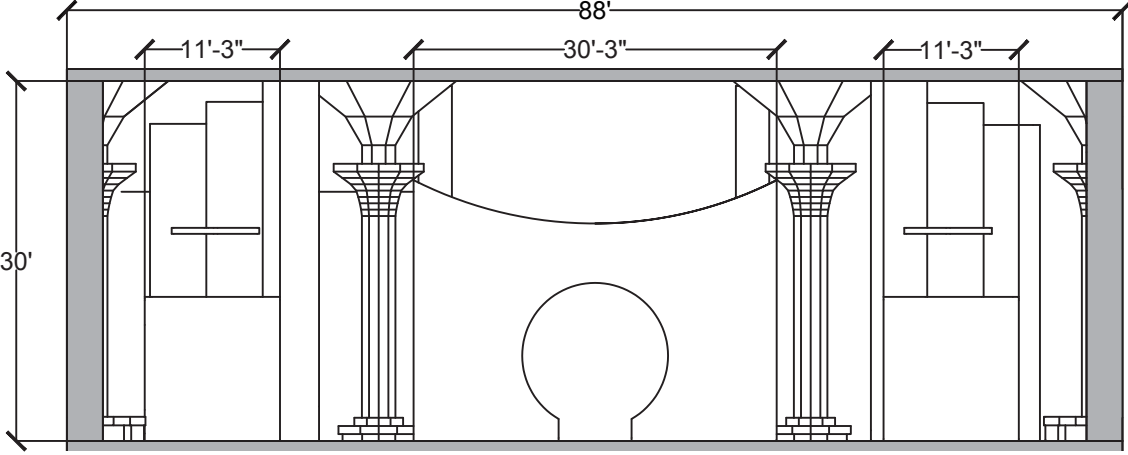

2 Overall Section B
1/16" = 1'-0"

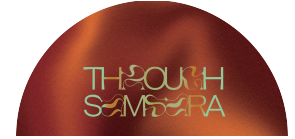

PROJECT
THROUGH SAMBARA

DRAWN BY
SUJIN HWANG

SITE
60 WALL STREET
ARTRIUM, NYC

CLIENT
BLOOMBERG
PHILANTHROPIES

NOTES
DRAWINGS FOR
DESIGN INTENT ONLY

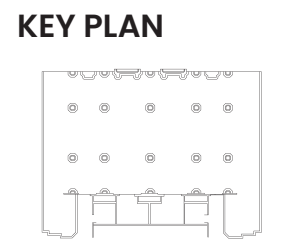

DATE
DEC 12, 2025

SCALE
AS NOTED

DRAWING
OVERALL SECTIONS

DRAWING NO.
EX.03.06

GRAPHIC ELEMENTNS



SUJIN HWANG



PROJECT
THROUGH SAMSARA

DRAWN BY
SUJIN HWANG

SITE
60 WALL STREET
ARTRIUM, NYC

CLIENT
BLOOMBERG
PHILANTHROPIES

NOTES
DRAWINGS FOR
DESIGN INTENT ONLY

KEY PLAN

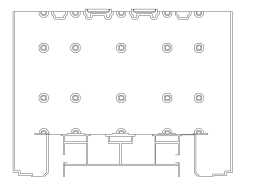

DATE
DEC 12, 2025

SCALE
AS NOTED

DRAWING
GRAPHIC ELEMENTS

DRAWING NO.
EX.04.01

GRAPHIC LOOK & FEEL



THROUGH
SAMSARA

VISUAL COMMUNICATION BRIEF

The graphics of Through Samsara express the idea of “moving through cycles.” Just like the title, it shows how people pass through repeated stress, emotions, and patterns – and arrive at a new sense of Zen.

The typography combines flowing shapes and solid forms, representing both our shifting inner state and the centered focus that comes from practice.



PROJECT
THROUGH SAMSARA

DRAWN BY
SUJIN HWANG

SITE
60 WALL STREET
ARTRIUUM, NYC

CLIENT
BLOOMBERG
PHILANTHROPIES

NOTES
DRAWINGS FOR
DESIGN INTENT ONLY

KEY PLAN

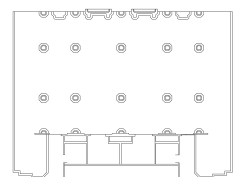

DATE
DEC 12, 2025

SCALE
AS NOTED

DRAWING
GRAPHIC LOOK &
FEEL

DRAWING NO.

EX.04.02

LOGO



COLORS



R 210
G 79
B 20



R 82
G 36
B 28



R 116
G 16
B 7



R 165
G 23
B 24



R 135
G 54
B 34



R 166
G 53
B 23

TYPOGRAPHY

TITLES

————— Doghebi + Polymath Light

HEADING

————— Polymath Bold

Subheading

————— Polymath Medium

Every day we move through repeating cycles of stress, emotion, and thought. Through Samsara reminds us that nothing stays fixed. When we allow things to pass instead of holding on, we create room for calm and clarity. Zen here isn't about leaving the city behind—it's about finding softness inside its constant motion.

————— Polymath Light

The brown–orange palette captures the energy of New York — the heat of the city, the metallic glow of the subway, and sunset light — while also creating the warm, meditative feeling of Zen.



PROJECT
THROUGH SAMSARA

DRAWN BY
SUJIN HWANG

SITE
60 WALL STREET
ARTRIUM, NYC

CLIENT
BLOOMBERG
PHILANTHROPIES

NOTES
DRAWINGS FOR
DESIGN INTENT ONLY

KEY PLAN

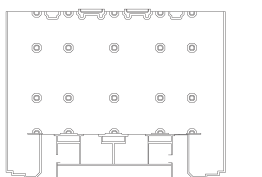

DATE
DEC 12, 2025

SCALE
AS NOTED

DRAWING
LOGO &
TYPOGRAPHY

DRAWING NO.
EX.04.03



SUJIN HWANG



PROJECT
THROUGH SAMSARA

DRAWN BY
SUJIN HWANG

SITE
60 WALL STREET
ARTRIUUM, NYC

CLIENT
BLOOMBERG
PHILANTHROPIES

NOTES
DRAWINGS FOR
DESIGN INTENT ONLY

KEY PLAN

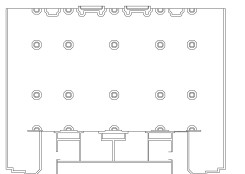

DATE
DEC 12, 2025

SCALE
AS NOTED

DRAWING
EXTERIOR POSTERS

DRAWING NO.
EX.04.04

EXHIBIT AREA DETAILS



SUJIN HWANG



PROJECT
THROUGH SAMSARA

DRAWN BY
SUJIN HWANG

SITE
60 WALL STREET
ARTRIUM, NYC

CLIENT
BLOOMBERG
PHILANTHROPIES

NOTES
DRAWINGS FOR
DESIGN INTENT ONLY

KEY PLAN

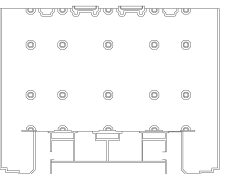

DATE
DEC 12, 2025

SCALE
AS NOTED

DRAWING
DETAILS

DRAWING NO.
EX.05.01

GRAPHIC TYPE

WHAT IS ZEN

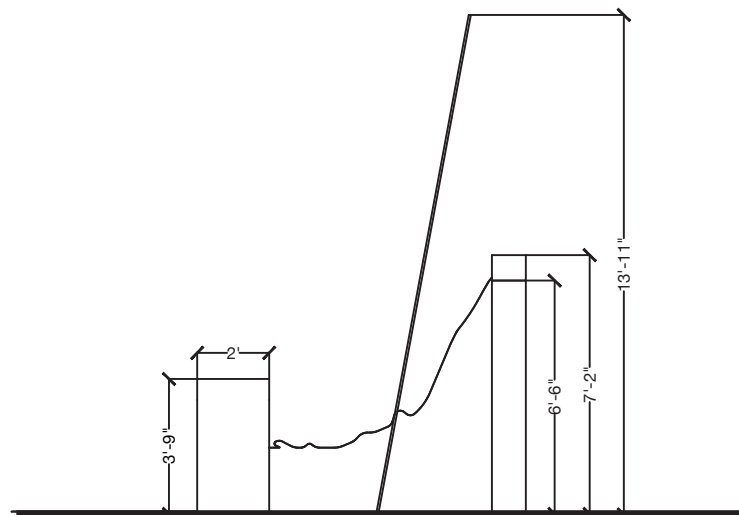
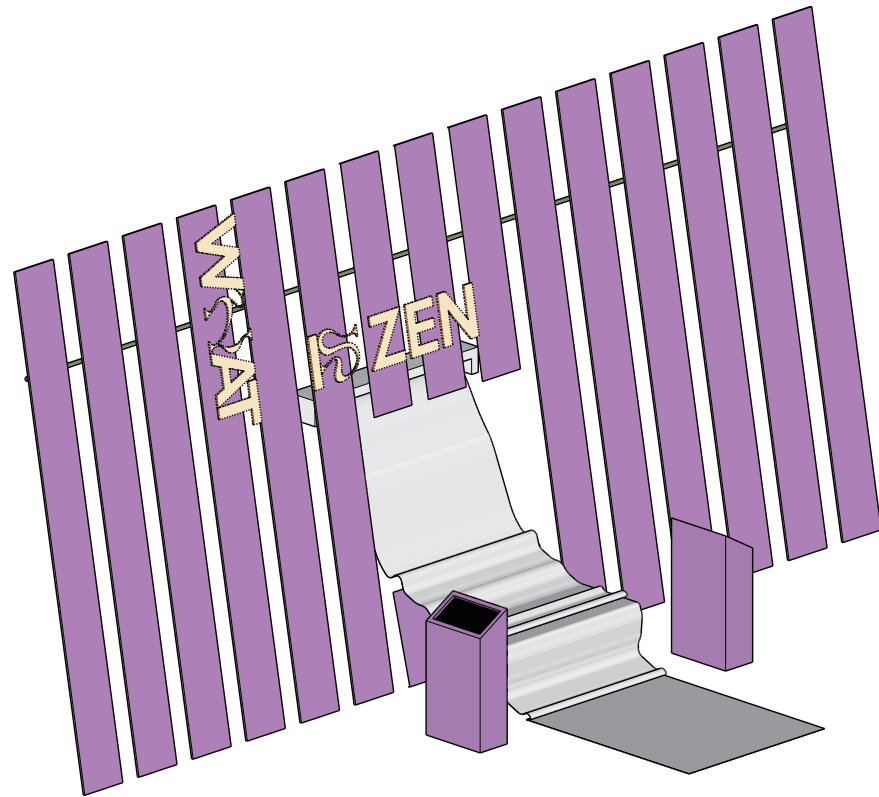

2 Side Elevation 02A.01.GR01-GR02
3/16" = 1'-0"

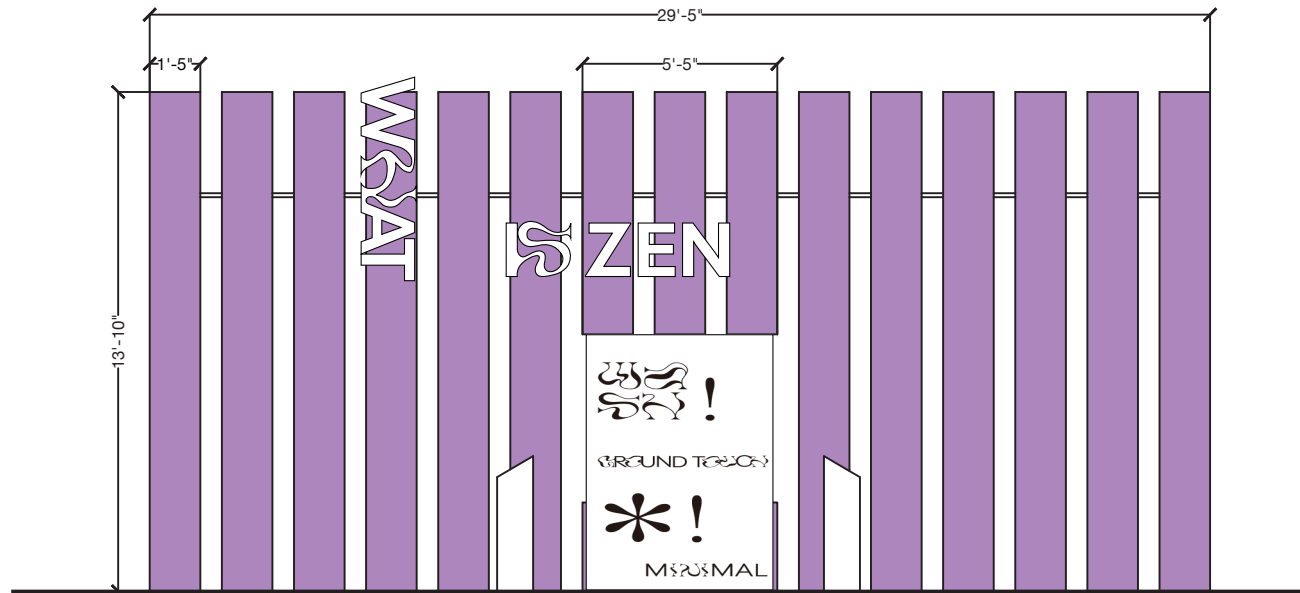

1 Graphic Elevation 02A.01.GR01-GR02
3/16" = 1'-0"

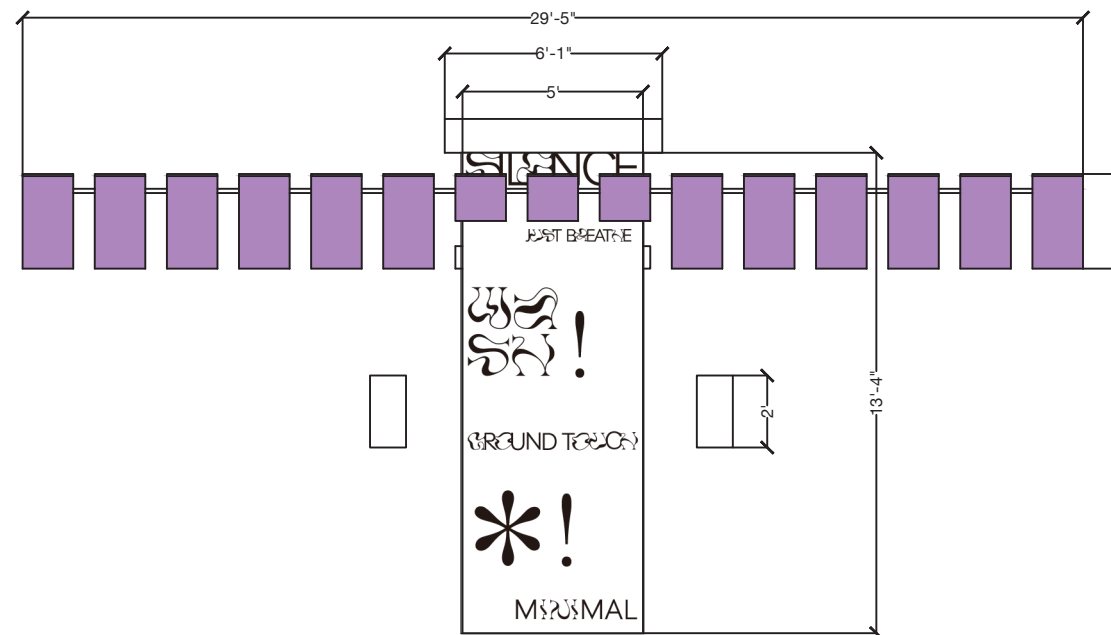

3 Graphic Plan 02A.01.GR01-GR02
3/16" = 1'-0"

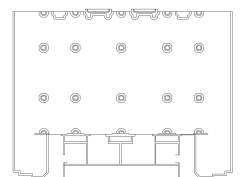



PROJECT
THROUGH SAMSARA

DRAWN BY
SUJIN HWANG

SITE
60 WALL STREET
ARTRIUM, NYC

CLIENT
BLOOMBERG
PHILANTHROPIES

NOTES
DRAWINGS FOR
DESIGN INTENT ONLY

KEY PLAN

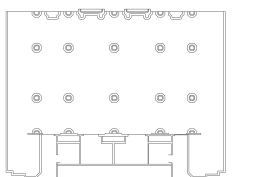

DATE
DEC 12, 2025

SCALE
AS NOTED

DRAWING
DETAILS

DRAWING NO.
EX.05.03

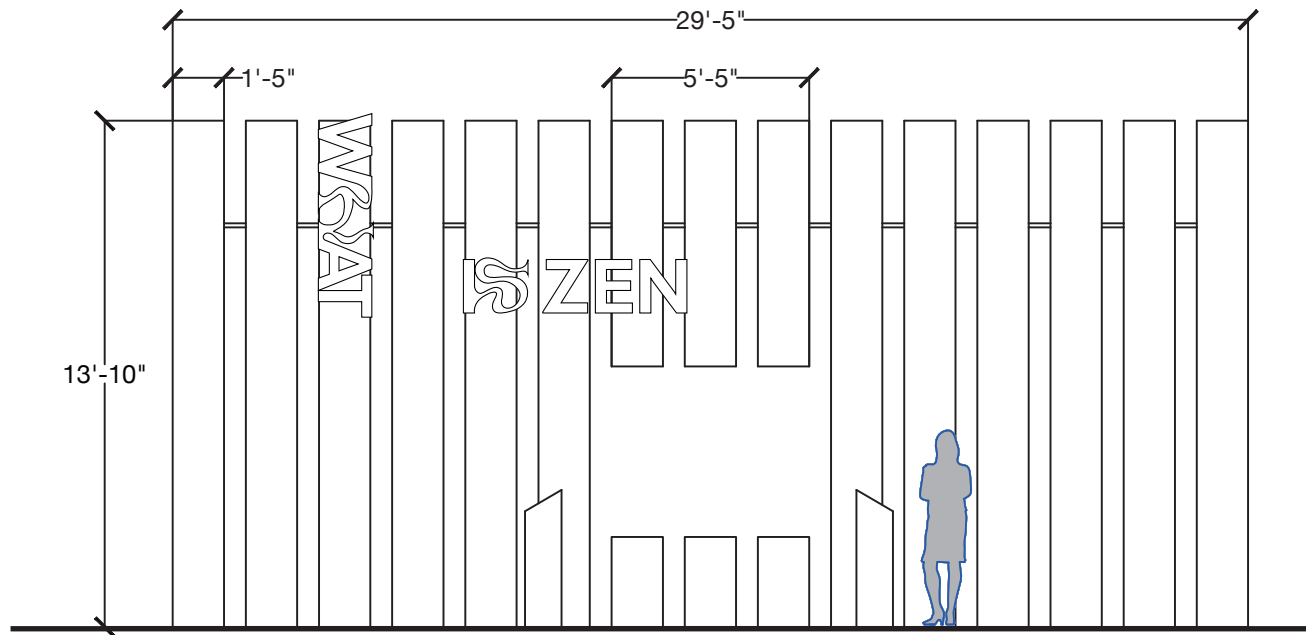

1 Elevation
3/16" = 1'-0"

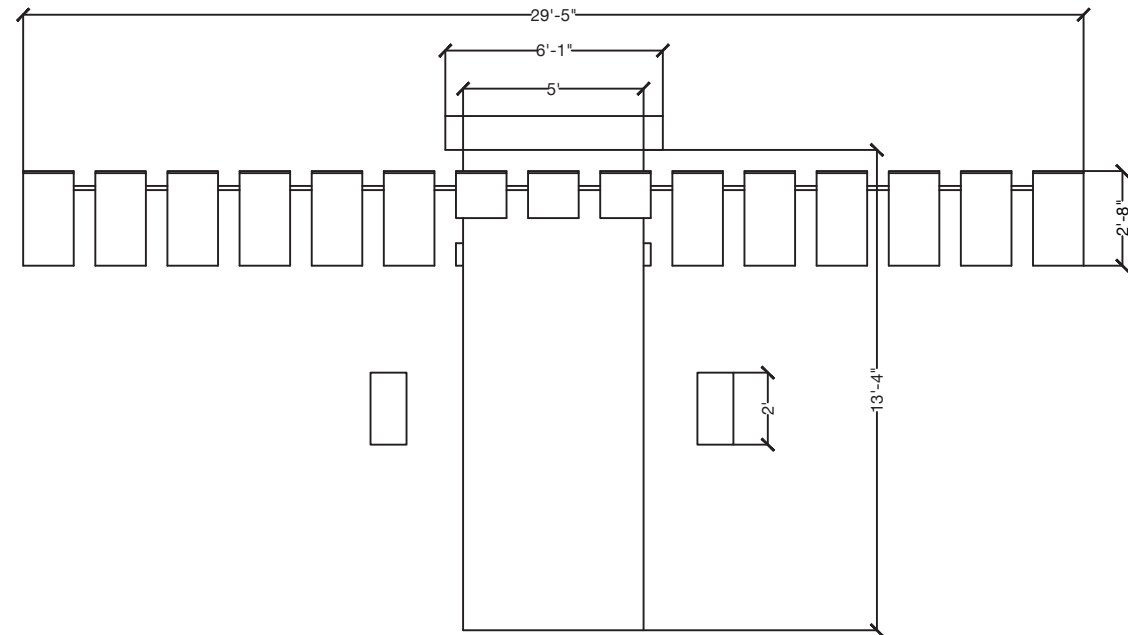

3 Plan
3/16" = 1'-0"

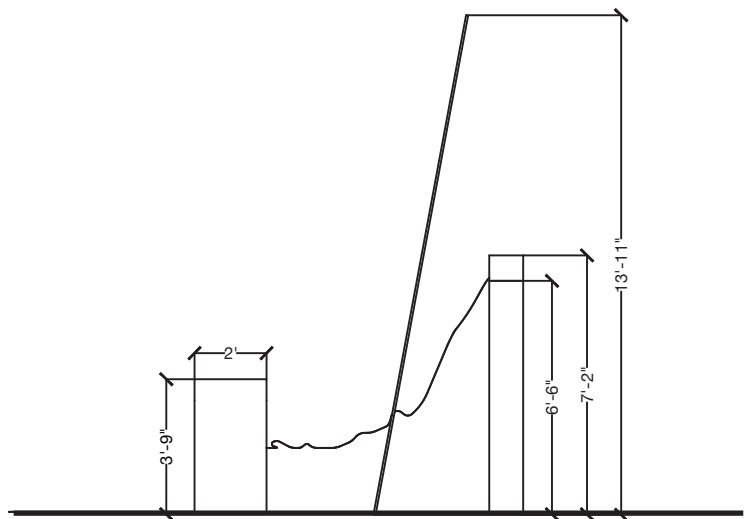

2 Side Elevation
3/16" = 1'-0"

GRAPHIC TYPE

CONSUMABLE ZEN

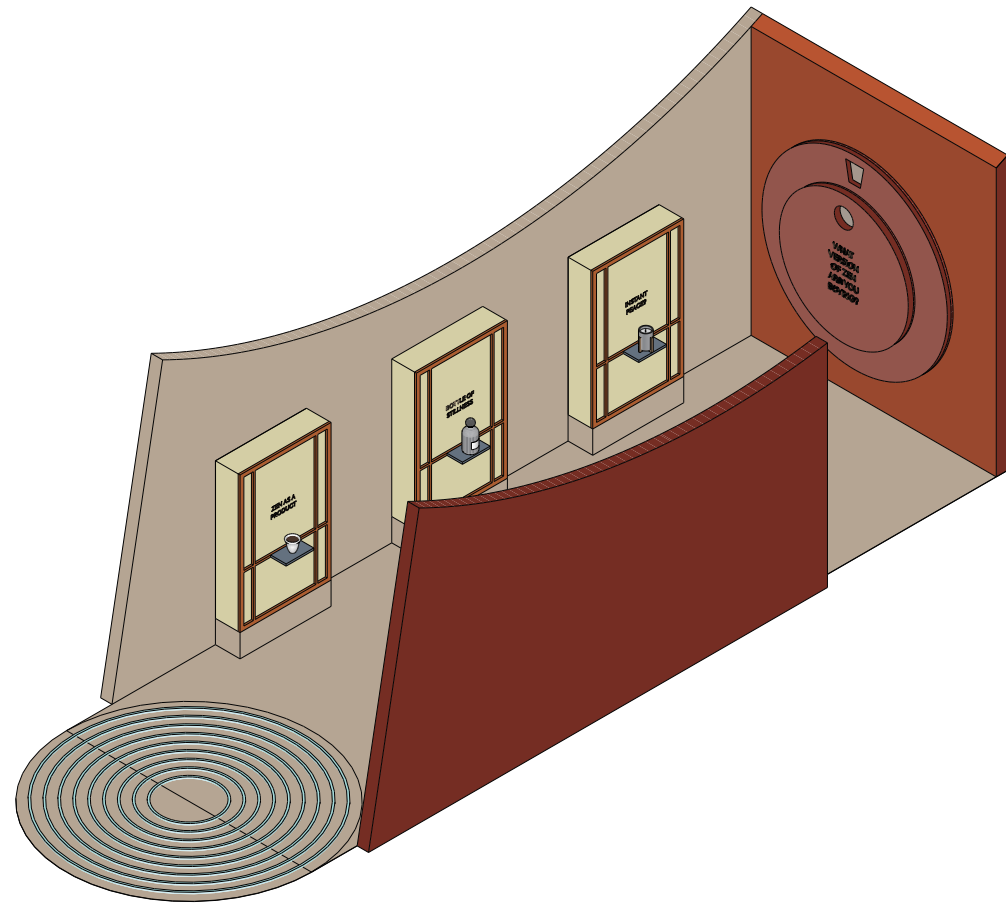

1 Graphic Elevation 03A.03.GR01-GR03
3/16" = 1'-0"

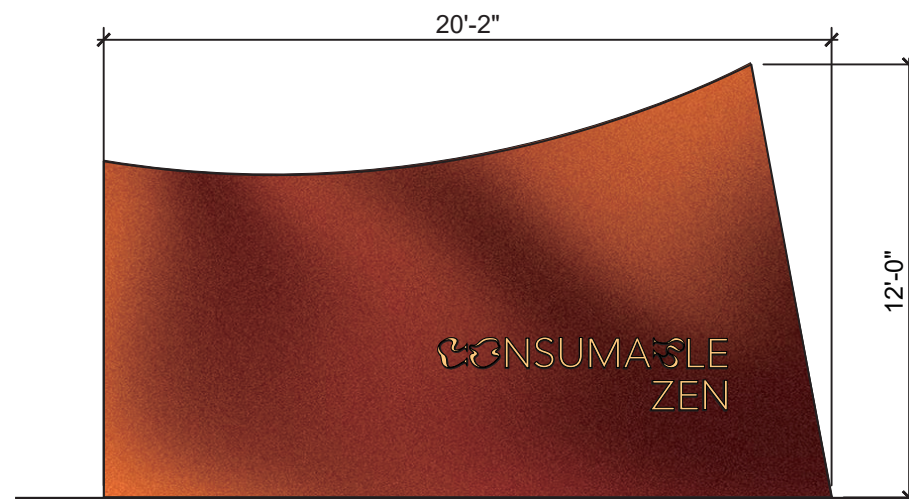

2 Graphic Elevation 2 03A.03.GR01-GR03
3/16" = 1'-0"

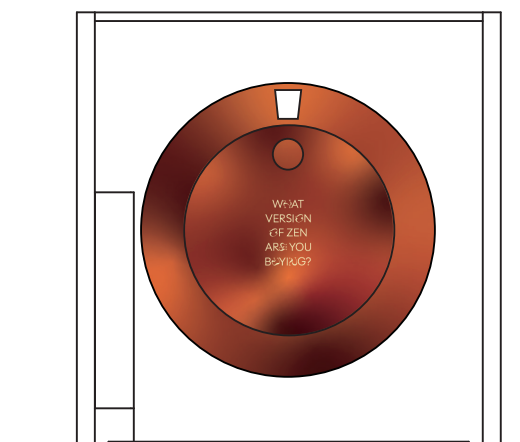

3 Graphic Side Elevation 03A.03.GR01-GR03
3/16" = 1'-0"

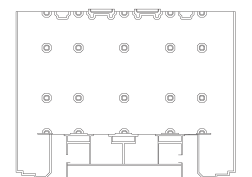



PROJECT
THROUGH SAMSARA

DRAWN BY
SUJIN HWANG

SITE
60 WALL STREET
ARTRIUM, NYC

CLIENT
BLOOMBERG
PHILANTHROPIES

NOTES
DRAWINGS FOR
DESIGN INTENT ONLY

KEY PLAN

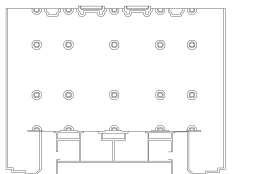

DATE
DEC 12, 2025

SCALE
AS NOTED

DRAWING
DETAILS

DRAWING NO.
EX.05.05

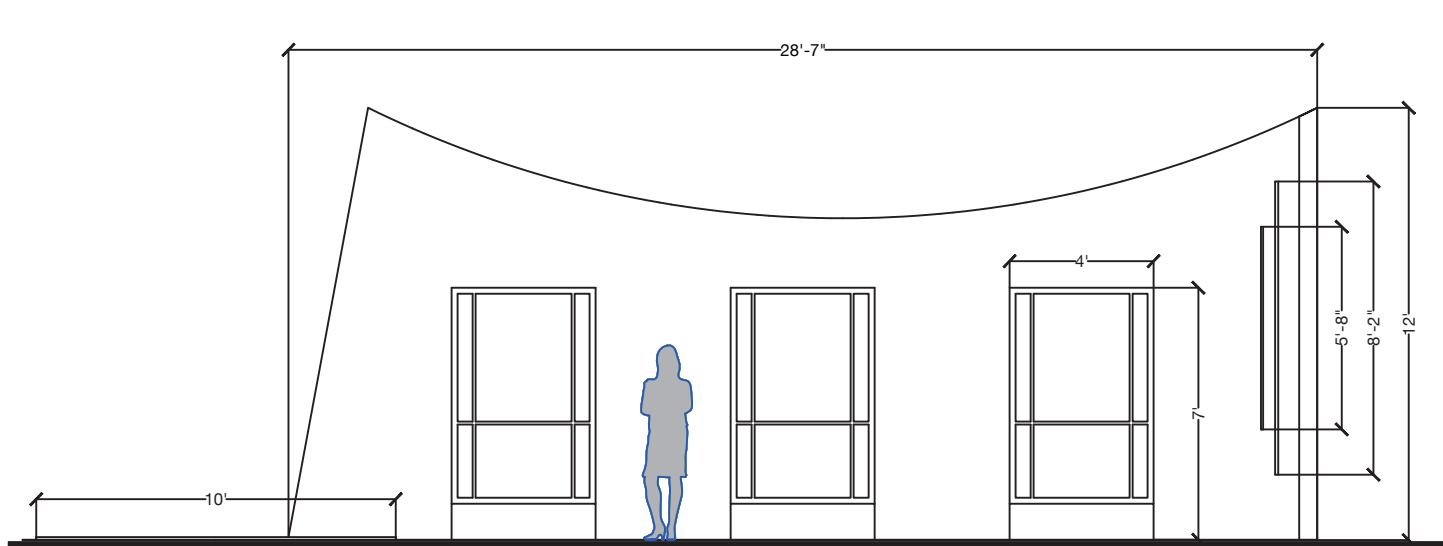

1 Elevation
3/16" = 1'-0"

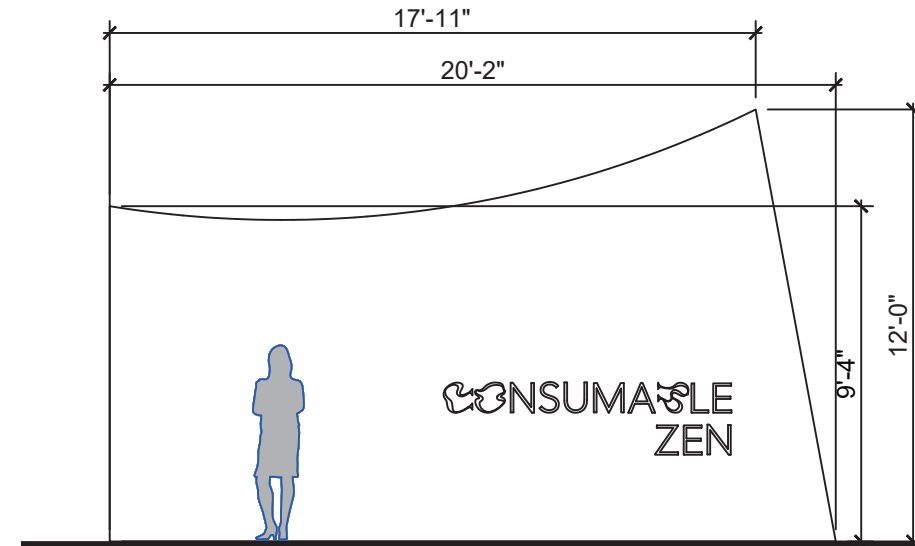

2 Elevation 2
3/16" = 1'-0"

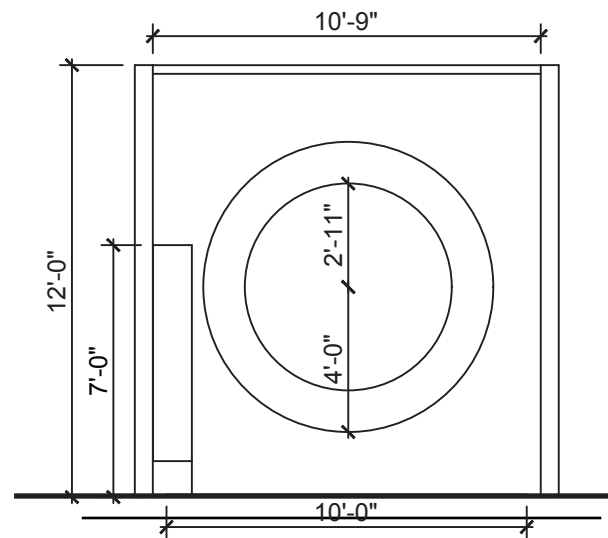

3 Side Elevation
3/16" = 1'-0"

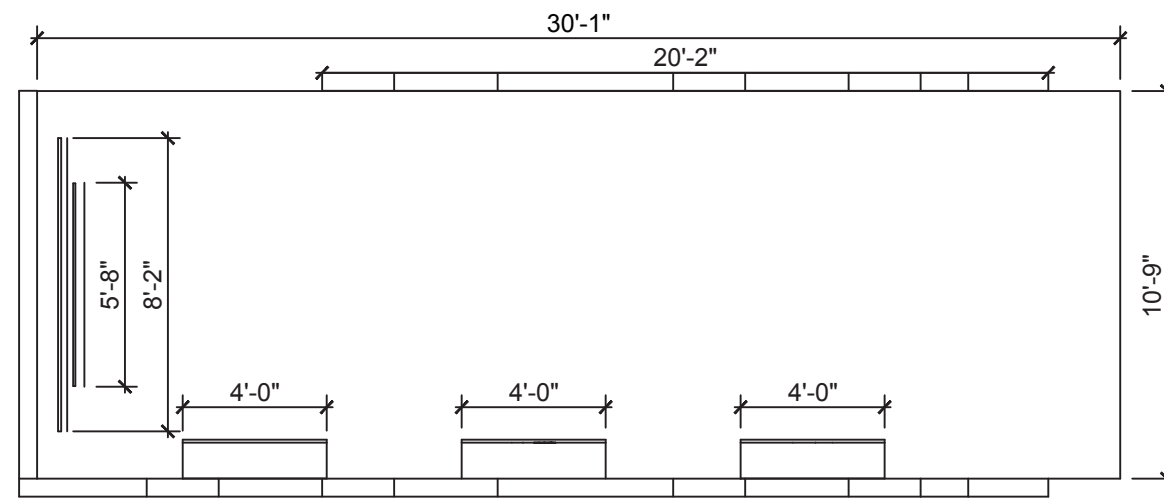

4 Plan
3/16" = 1'-0"

GRAPHIC TYPE

NOTHING HOLDS

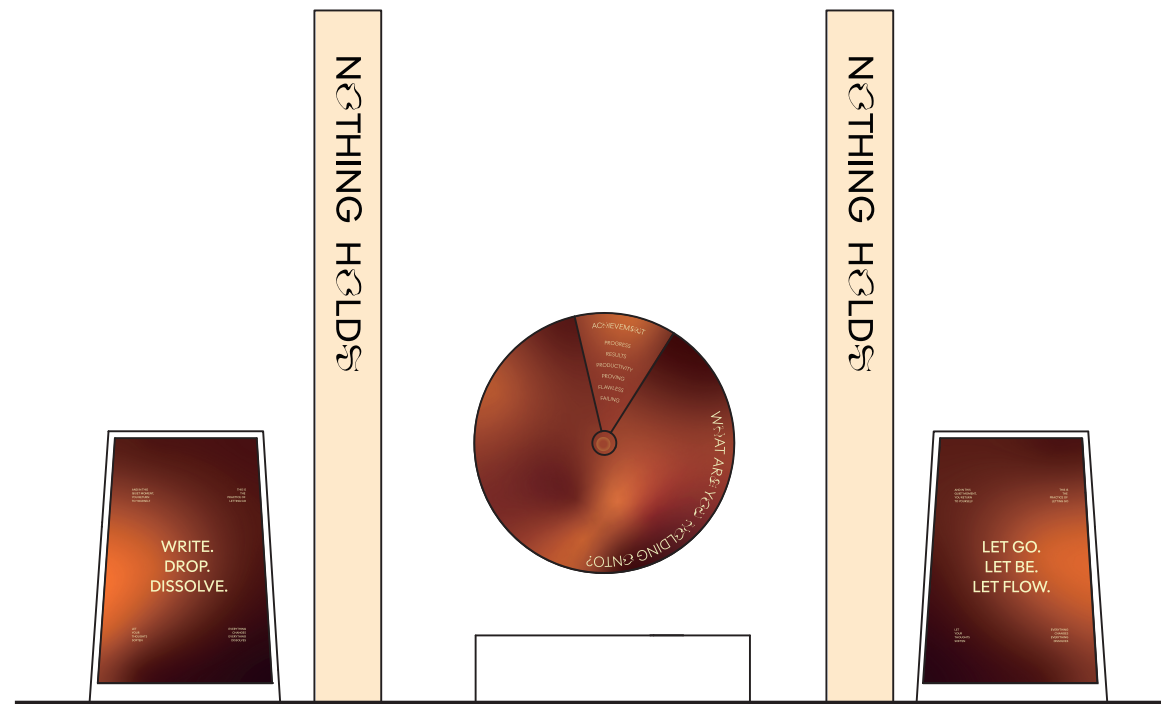
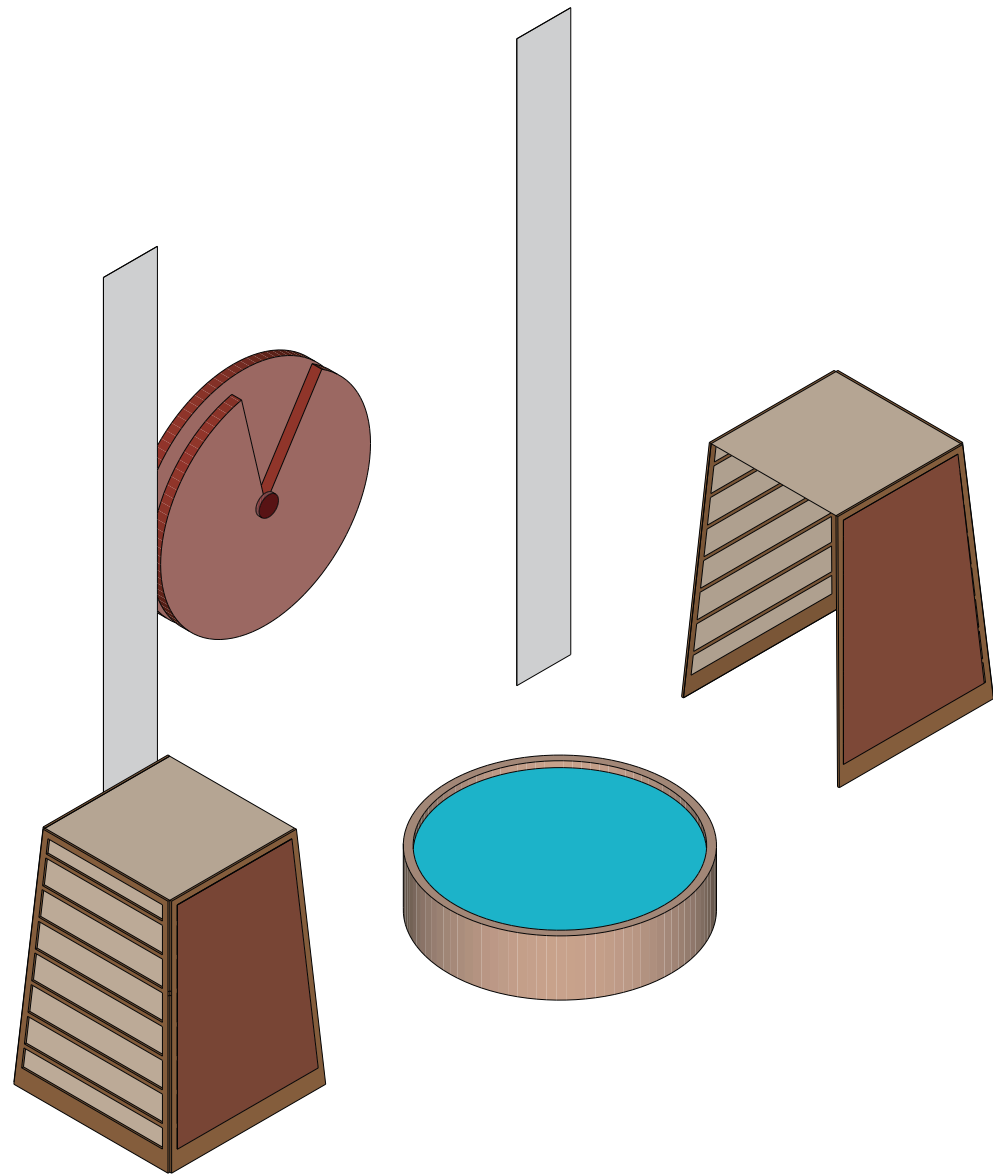

1 Graphic Elevation 05A.01.GR01-03.GR02
1/8" = 1'-0"



PROJECT
THROUGH SAMBARA

DRAWN BY
SUJIN HWANG

SITE
60 WALL STREET
ARTRIUM, NYC

CLIENT
BLOOMBERG
PHILANTHROPIES

NOTES
DRAWINGS FOR
DESIGN INTENT ONLY

KEY PLAN

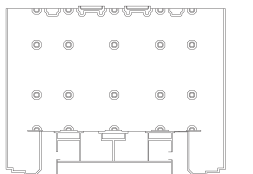

DATE
DEC 12, 2025

SCALE
AS NOTED

DRAWING
DETAILS

DRAWING NO.
EX.05.06



PROJECT
THROUGH SAMBARA

DRAWN BY
SUJIN HWANG

SITE
60 WALL STREET
ARTRIUUM, NYC

CLIENT
BLOOMBERG
PHILANTHROPIES

NOTES
DRAWINGS FOR
DESIGN INTENT ONLY

KEY PLAN

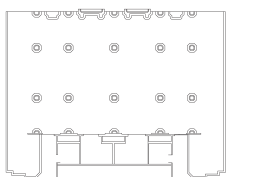

DATE
DEC 12, 2025

SCALE
AS NOTED

DRAWING
DETAILS

DRAWING NO.
EX.05.07

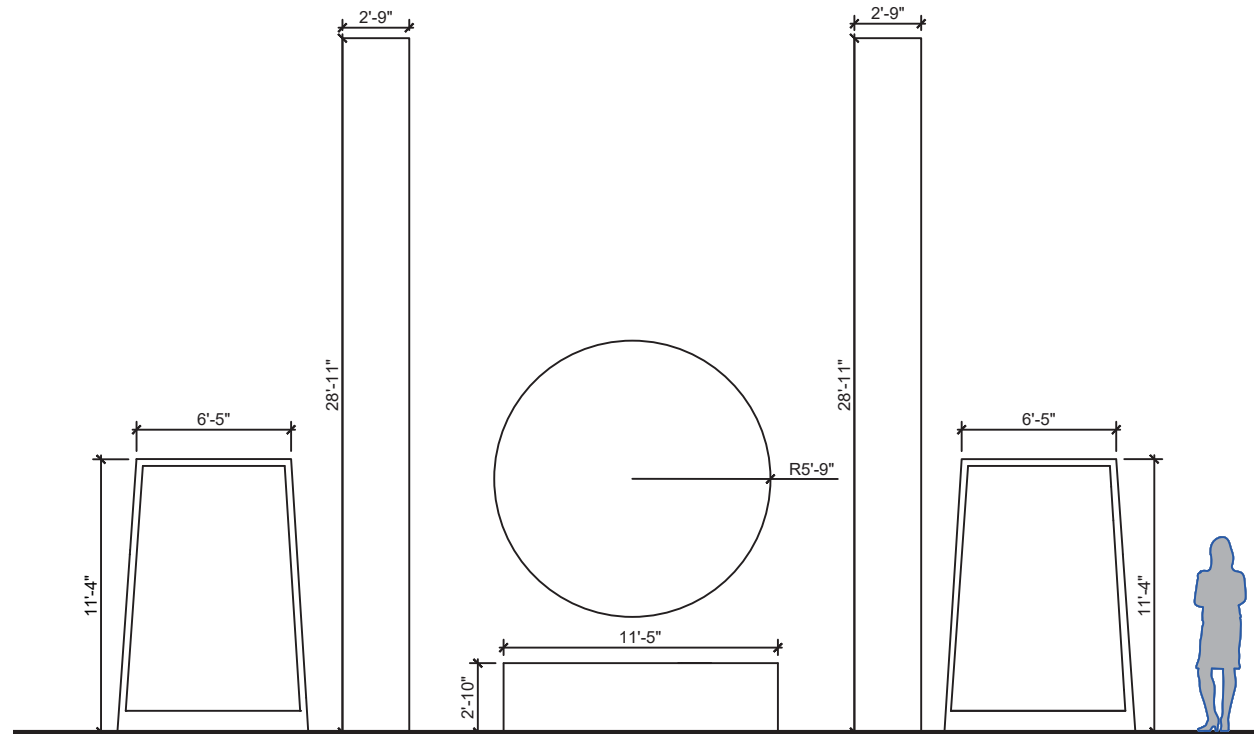

1 Elevation
1/8" = 1'-0"

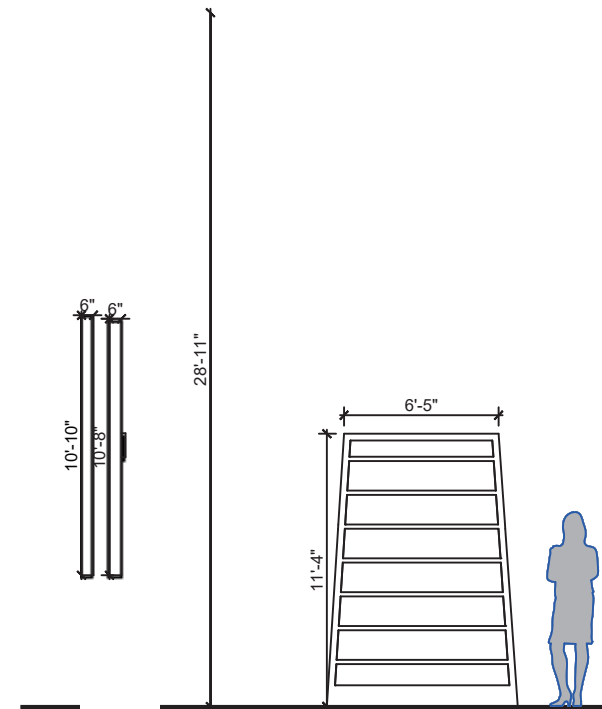

2 Side Elevation
1/8" = 1'-0"

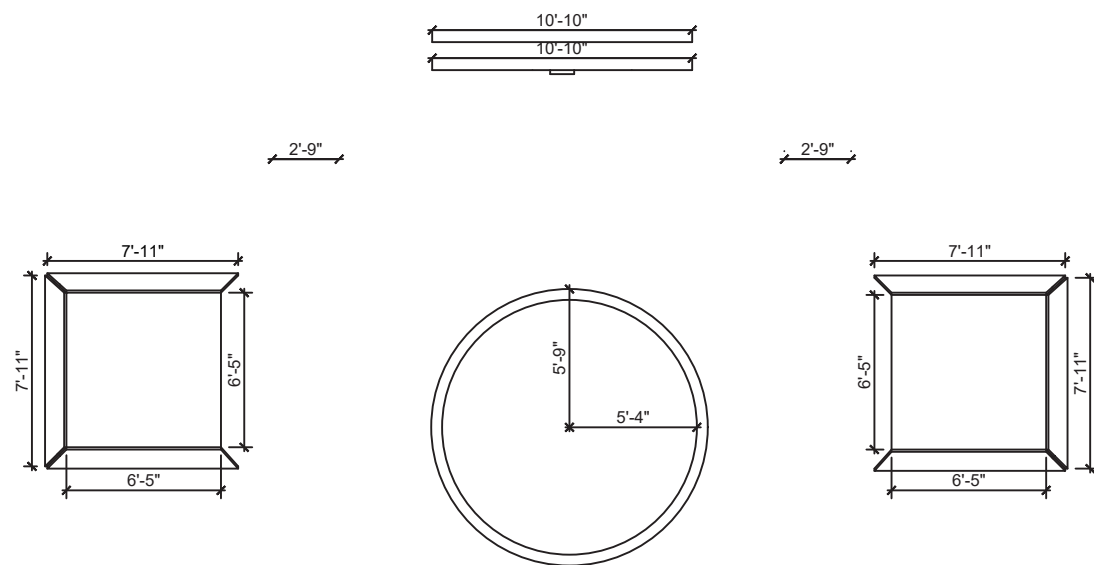

3 Plan
1/8" = 1'-0"

GRAPHIC TYPE BEGIN HERE

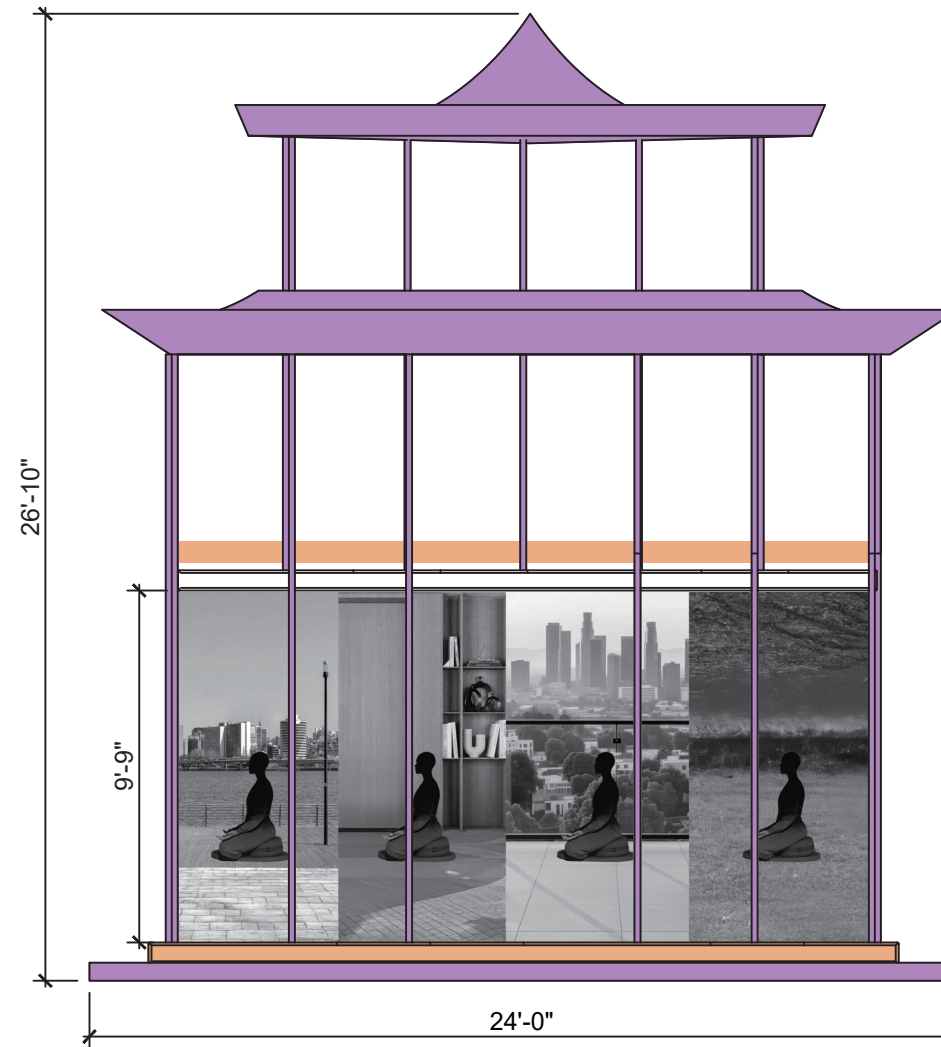
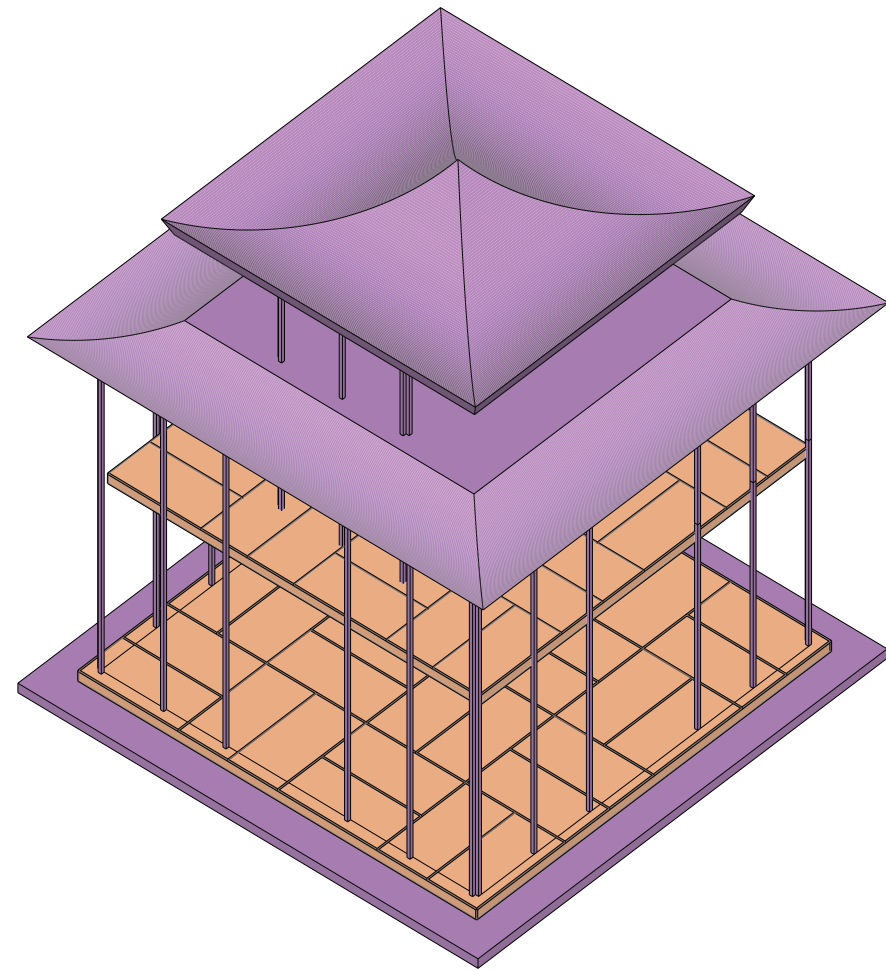

1 Graphic Elevation 09A.01.GR01
3/16" = 1'-0"



PROJECT
THROUGH SAMBARA

DRAWN BY
SUJIN HWANG

SITE
60 WALL STREET
ARTRIUUM, NYC

CLIENT
BLOOMBERG
PHILANTHROPIES

NOTES
DRAWINGS FOR
DESIGN INTENT ONLY

KEY PLAN

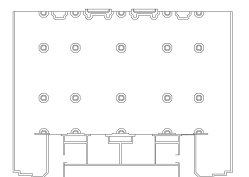

DATE
DEC 12, 2025

SCALE
AS NOTED

DRAWING
DETAILS

DRAWING NO.
EX.05.08



PROJECT
THROUGH SAMSARA

DRAWN BY
SUJIN HWANG

SITE
60 WALL STREET
ARTRIUM, NYC

CLIENT
BLOOMBERG
PHILANTHROPIES

NOTES
DRAWINGS FOR
DESIGN INTENT ONLY

KEY PLAN

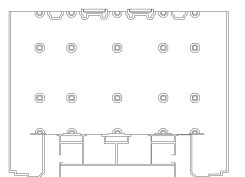

DATE
DEC 12, 2025

SCALE
AS NOTED

DRAWING
DETAILS

DRAWING NO.
EX.05.09

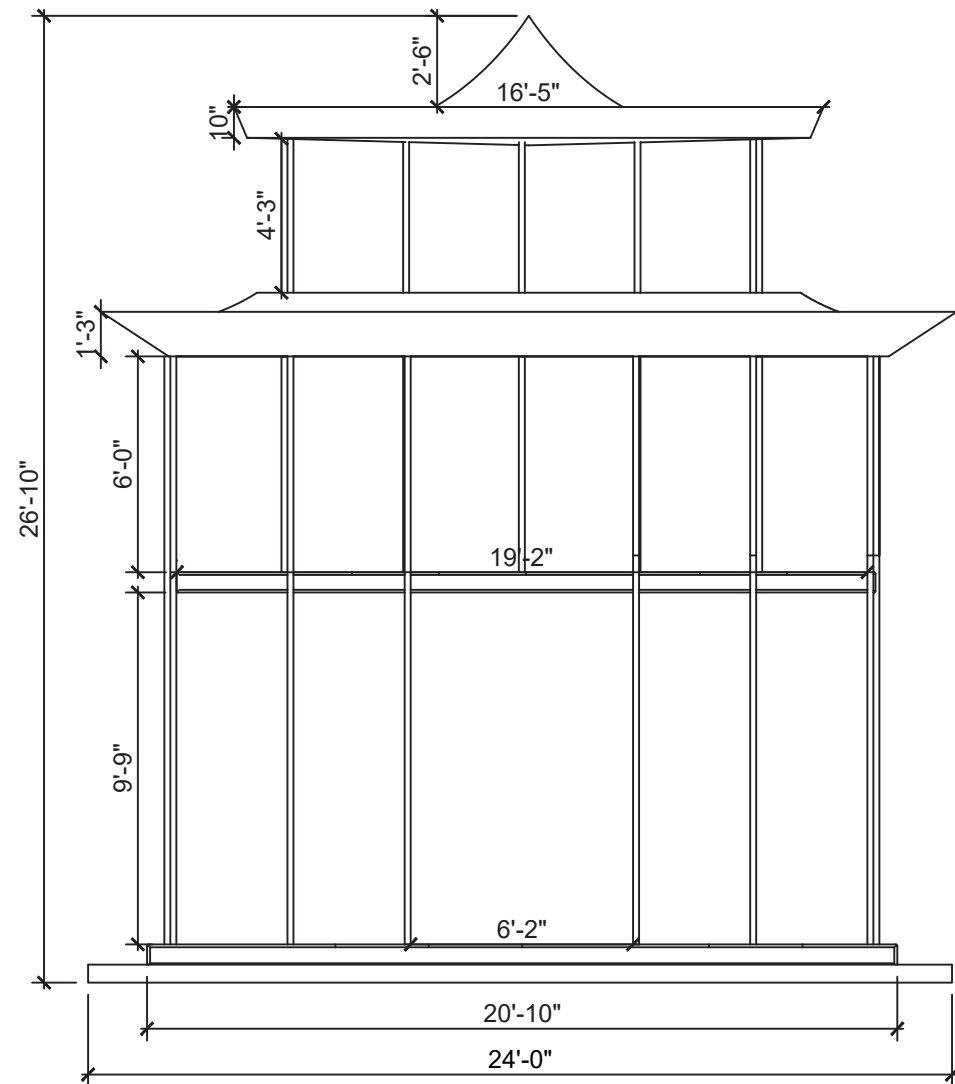

1 Elevation
3/16" = 1'-0"

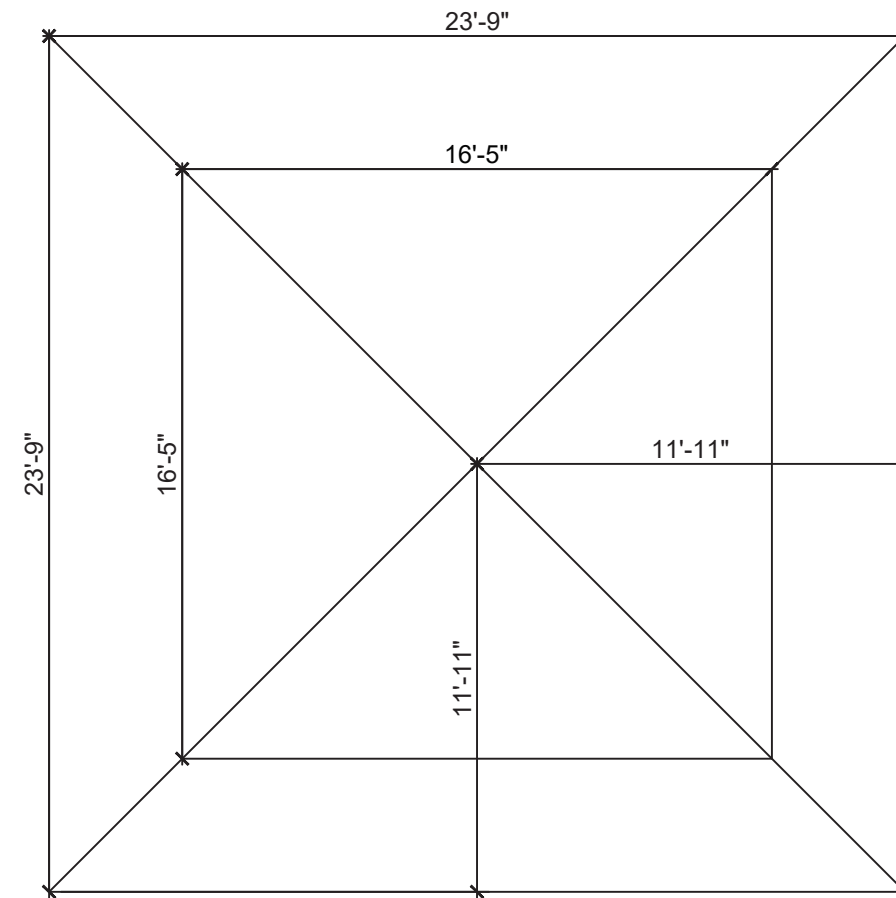

2 Plan
3/16" = 1'-0"